

So-PowerPoint® So-PP-S/So-PP-B/ So-PP-VIP

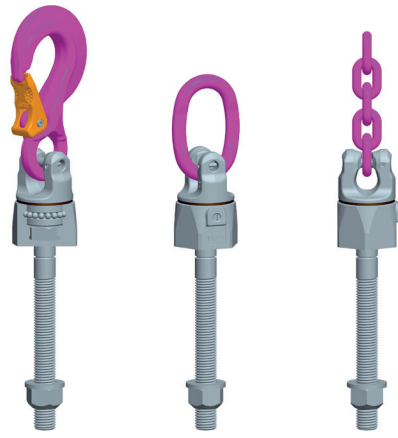

Safety instructions

This safety instruction/declaration of the manufacturer has to be kept on file for the whole lifetime of the product.
Translation of the Original instructions



RUD Ketten
Rieger & Dietz GmbH u. Co. KG
73428 Aalen
Tel. +49 7361 504-1370
Fax +49 7361 504-1171
sliding@rud.com
www.rud.com

RUD-Art.-Nr.: 7997128-EN / 06.020

lifting Points for bolting
double ballbearing
**Special-PP-S/Special-PP-B/
Special-PP-VIP**

EG-Konformitätserklärung

entsprechend der EG-Maschinenrichtlinie 2006/42/EG, Anhang II A und ihren Änderungen

Hersteller: **RUD Ketten
Rieger & Dietz GmbH u. Co. KG**
Friedensinsel
73432 Aalen

Hiermit erklären wir, dass die nachfolgend bezeichnete Maschine aufgrund ihrer Konzipierung und Bauart, sowie in der von uns in Verkehr gebrachten Ausführung, den grundlegenden Sicherheits- und Gesundheitsanforderungen der EG-Maschinenrichtlinie 2006/42/EG sowie den unten aufgeführten harmonisierten und nationalen Normen sowie technischen Spezifikationen entspricht.
Bei einer nicht mit uns abgestimmten Änderung der Maschine verliert diese Erklärung ihre Gültigkeit.

Produktbezeichnung: Anschlagpunkt PowerPoint
PP / WPP / WPPH

Folgende harmonisierten Normen wurden angewandt:

<u>DIN EN 1677-1 : 2009-03</u>	<u>DIN EN 1677-4 : 2009-03</u>
<u>DIN EN ISO 12100 : 2011-03</u>	
_____	_____
_____	_____

Folgende nationalen Normen und technische Spezifikationen wurden außerdem angewandt:

<u>BGR 500, KAP2.8 : 2008-04</u>	_____
_____	_____
_____	_____

Für die Zusammenstellung der Konformitätsdokumentation bevollmächtigte Person:
Michael Betzler, RUD Ketten, 73432 Aalen

Aalen, den 26.09.2016 Dr.-Ing. Arne Kriegsmann (Prokurist/QMB)
Name, Funktion und Unterschrift Verantwortlicher *Arne Kriegsmann*

EC-Declaration of conformity

According to the EC-Machinery Directive 2006/42/EC, annex II A and amendments

Manufacturer: **RUD Ketten
Rieger & Dietz GmbH u. Co. KG**
Friedensinsel
73432 Aalen

We hereby declare that the equipment sold by us because of its design and construction, as mentioned below, corresponds to the appropriate, basic requirements of safety and health of the corresponding EC-Machinery Directive 2006/42/EC as well as to the below mentioned harmonized and national norms as well as technical specifications.
In case of any modification of the equipment, not being agreed upon with us, this declaration becomes invalid.

Product name: Lifting point PowerPoint
PP / WPP / WPPH

The following harmonized norms were applied:

<u>DIN EN 1677-1 : 2009-03</u>	<u>DIN EN 1677-4 : 2009-03</u>
<u>DIN EN ISO 12100 : 2011-03</u>	
_____	_____
_____	_____

The following national norms and technical specifications were applied:

<u>BGR 500, KAP2.8 : 2008-04</u>	_____
_____	_____
_____	_____

Authorized person for the configuration of the declaration documents:
Michael Betzler, RUD Ketten, 73432 Aalen

Aalen, den 26.09.2016 Dr.-Ing. Arne Kriegsmann (Prokurist/QMB)
Name, function and signature of the responsible person *Arne Kriegsmann*



Before every use, please read the Safety Instruction of the Special-Power-Point® carefully and make sure that you understand all substance.

Improper use or care of this eyebolt can result in bodily injury or property damage and eliminates any warranty!

1 Application and warning information



WARNING

Improper assembled or damaged Special-PowerPoint® and inappropriate use can result in deadly injury or lead to heavy injuries and property damage when load drops. Inspect the Special-PowerPoint® before each use carefully!

- The Special-PowerPoint® must only be used by competent and trained people with adequate knowledge respecting DGUV 100-500 requirements, and outside Germany the corresponding country specific requirements must be utilised.
- Any combinations with eye and chain components which are not from RUD is prohibited. These combinations are not designated and can lead to component failure.



Hint

For the user it is forbidden to disassemble the ball bearing.

2 Intended use of Special-PowerPoint®

Special-PowerPoint® Lifting Points must only be used for lifting of loads and for the total WLL according to the stated inclination angles.

Turning and rotating of loads is permitted due to the ball bearing. Permanent-turning under load is not permitted.

The Special-PowerPoint® must only be used in the hereby specified application.

3 Versions

RUD Special-PowerPoint® are available in the following versions:

- **Special-PP-S:** the standard version
- **Special-PP-B:** the lifting ring version for hook assemblies
- **Special-PP-VIP:** the direct chain connection



Pic. 1: Sp-PP-S Sp-PP-B Sp-PP-VIP



Hint

Any combinations with eye and chain components which are not from RUD is prohibited. Other combinations with non RUD components and chains are dangerous! These are not permitted and RUD will not accept any warranty.

- The Special-PowerPoint® versions are available with

different thread lengths (refer to F_{vario} in table 1) and have partially reduced WLL, when assembled from the side. Please note component markings.

The assembly of components must only be carried out by RUD or by authorised specialists.

3 Installation information

3.1 General information

- Effect of temperature:
 - Due to the greasing (inside the ball bearing) we recommend to use Special-PowerPoint®-versions not in overheated areas. If this cannot be avoided please take the reduced WLL into consideration:
 - 40° up to 100°C: no reduction
 - 100° up to 200°C: minus 15 % (212°F up to 392°F)
 - 200° up to 250°C: minus 20 % (392°F up to 482°F)
 - 250° up to 350°C: minus 25 % (482°F up to 662°F)
 - Temperatures above 350°C (662°F) are not allowed.** Please pay attention when using DIN EN 7042 (DIN 980) nuts the max. operation temperature of 150°C (acc. to DIN EN ISO 2320).
- RUD lifting points must not be used under chemical influences such as acids, alkaline solutions and vapours e.g. in pickling baths or hot dip galvanising plants. If this cannot be avoided, please contact the manufacturer indicating the concentration, period of penetration and temperature of use.
- The special fluorescent pink powder coating of the fittings permanently changes its colour during the use in higher temperatures areas. A deep black colour indicates the use beyond 360°C.



HINT

Once used in temperature > 360°C (black colour occurs on the chain) any further usage is forbidden.

The quality grade of the chain is no longer be given.

3.2 Assembly information

1. The material construction to which the lifting point will be attached should be of adequate strength to withstand forces during lifting without deformation. The German testing authority BG, recommends the following minimum for the bolt lengths:
 - 1 x M in steel (min. quality S235JR [1.0037])
 - 1,25 x M in cast iron (e.g. GG25)
 - 2 x M in aluminium
 - 2,5 x M in aluminium-magnesium alloys (M = thread Ø, e.g. M 20)
2. When lifting light metals, nonferrous metals and gray cast iron the thread has to be chosen in such a way that the WLL of the thread corresponds to the requirements of the corresponding base material.
3. The lifting points must be positioned to the load in such a way that movements are avoided during lifting.
 - **For single leg lifts**, the lifting point should be vertically above the centre of gravity of the load.
 - **For two leg lifts**, the lifting points must be equidistant to/or above the centre of gravity of the load.
 - **For three and four leg lifts**, the lifting points should be arranged symmetrical around the centre of gravity, in the same plane if possible.

- A plane bolt-on surface (with a minimum $\varnothing D$) with a perpendicular machined thread hole must be given. The thread has to be machined acc. to DIN 76 (countersink max. 1.05xd).

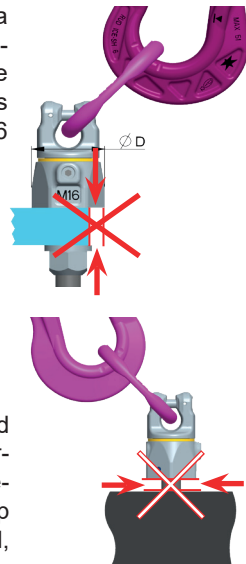

Pic. 2: Thread of the Sp-PP must be completely engaged and the lifting point must be installed full-faced. (The diameter of the bearing surface must be $\geq D$)

- Thread holes must be machined deep enough that the supporting area of the lifting point bears. Machine through holes up to DIN EN 20273-middle (Md, compare chart 1).

Pic. 3: Sp-PP must have been fully bolted in.

- The position where the lifting points should be attached should be clearly marked with colour.
- Load symmetry:
The required WLL of the individual RUD lifting point are calculated using the following formula and are based on symmetrical loading:

$W_{LL} = \frac{G}{n \times \cos \beta}$	WLL = working load limit / capacity of each lifting point G = load weight (kg) n = number of load bearing legs β = angle of inclination of the chain to the vertical	
	The calculation of the load bearing legs is as follows:	
	symmetrical	unsymmetrical
two leg	2	1
three / four leg	3	1

(also refer to table 2)

- Due to the ball bearing, for a single use, it is sufficient to tighten by hand with a spanner, without using an extension. For long term application the Special-PowerPoint[®] should be tightened with torque according table 1 (+/- 10 %).
- All fittings connected to the Special-PowerPoint[®]-versions should be free moving. Also the assembled components on the Special-PowerPoint[®] must be free moveable and should not used over sharp corners.



Hint

To prevent unintended dismounting through shock loading, rotation or vibrations thread locking devices are recommended. Therefore different locking systems are possible. Liquid locking fluid such as Loctite (respect manufacturer specifications) or form closed versions such as hex castel nut, counter nut, etc.

- For lifting points which remains on the construction we basically recommend to secure with liquid locking device and tighten with torque.
- If the lifting points are used **exclusively** for lashing the value of the working load limit can be doubled: $LC = 2 \times WLL$
- The RUD Sp-PowerPoint must not be loaded with the Manufacturing Proof Force MPF (2.5 x WLL). Should at the production of lifting means or similar products, a singular proof loading be necessary, please ask RUD in advance.

- Finally check after the installation the ongoing ability of the lifting point by a competent person (see chapter 4 Inspection criteria).

3.3 User information

- Before installation and every use, inspect visually RUD lifting points, paying particular attention to any evidence of corrosion, wear, weld cracks and deformations. Please ensure compatibility of bolt thread and tapped hole (see chapter 4 Inspection criteria).



WARNING

Improper assembled or damaged Special-PowerPoint[®] and inappropriate use can result in deadly injury or lead to heavy injuries and property damage when load drops. Inspect the Special-PowerPoint[®] before each use carefully!

- When connecting and disconnecting the lifting means (wire ropes, chain slings, round slings) pinches and impacts should be avoided. Damage of the lifting means caused by sharp corners should be avoided as well.
- Before lifting the hooks must be installed without twists in the direction of pull.
- Ring/hook/chain of the adjusted PP-Special can be pivot by 230° (Pic. 4). To guarantee the WLL and the function (compare table 2), the inclination angle of the ring/hook/chain must not exceed 25° when lifting point is attached from the side (compare Pic. 5).



ATTENTION

Ring/hook/chain resp. the attached lifting mean must be free moveable in the PP-Special and must neither have support at the load edge nor at the bottom part of the PP-Special.

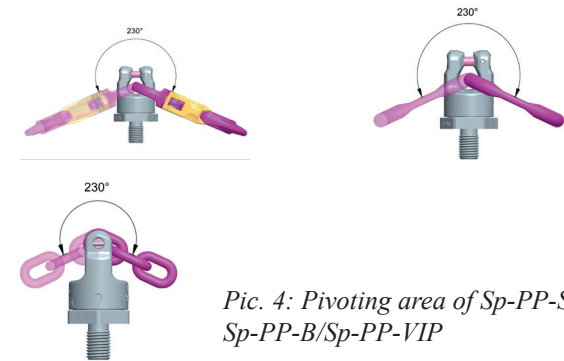

Pic. 4: Pivoting area of Sp-PP-S/Sp-PP-B/Sp-PP-VIP

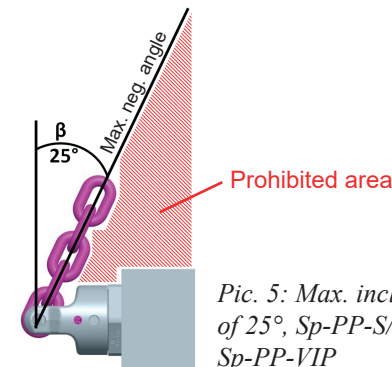

Pic. 5: Max. inclination angle of 25°, Sp-PP-S/Sp-PP-B/Sp-PP-VIP

3.4 Hints for the regular inspection

In time periods complying to the need or usage a technical expert should control at least once a year the appropriateness of the lifting point. This inspection must also be done after each event of damage or special incident.



Hint

*Translation of the original instruction manual
In case of doubts or misunderstandings, the
German version of the document is decisive.*

4 Inspection criteria

Observe and control the following points before each usage in regular periods, after assembly and after special incidents:

- Ensure correct bolt size, quality and length
- Ensure compatibility of bolt thread and tapped hole - control of the torque
- The lifting point should be complete
- The WLL, thread size, batch code and manufacturers stamping should be clearly visible on the lifting point.
- Deformations of the components parts such as body, fittings and thread.
- Mechanical damages such as notches, especially in high stress areas.
- Wear should be not more than 10 % of cross sectional diameter.
- Evidence of corrosion.
- Damage to the bolt and/or thread
- The upper fork head part of the Special-PowerPoint®-versions must rotate smoothly
- The Special-PowerPoint®-versions should only be used within the nom WLL. See RUD chart
- Magnetic crack test only.
- The maximum gap „S“ between upper- and lower part of the Special-PowerPoint® must not be exceeded (Pic. 6):
 - Sp-PP-...-0.63 t (0,6) up to Sp-PP-...-2.5t max. 1.5 mm
 - Sp-PP-...-3.5 t (4) up to Sp-PP-...-8 t (10) max. 2.5 mm

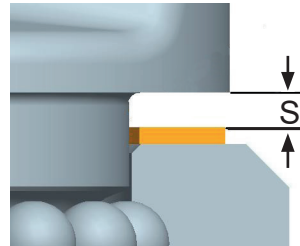

Pic. 6: Distance between upper and base part



Type	Thread	WLL [t]	A [mm]	B [mm]	C [mm]	D [mm]	E [mm]	F Vario [mm]	G [mm]	M [mm]	Md [mm]	T [mm]	torque	Ref.-no.	
 Sonder-PowerPoint-S (hook)	VIP 4 So-PP-S-0.6t (0.63)	M12	0.6 (0.63)	13	75	18	42	36	47	12-140	12	13.5	122	10 Nm	8600520
		M12 x 1.5								12x1.5					
		1/2"-13UNC								1/2"	14				
	VIP 6 So-PP-S-1.0t (1.5)	M14	1.0 (1.5)	20	97	25	48	41	58	14-160	14	15.5	155	25 Nm	8600521
		M14 x 1.5								14x1.5					
	VIP 6 So-PP-S-1.3t (1.5)	M16	1.3 (1.5)	20	97	25	48	41	58	16-180	16	17.5	155	30 Nm	8600522
		M16 x 1.5								16x1.5					
		5/8"-11UNC								5/8"					
	VIP 8 So-PP-S-2.0t (2.5)	M20	2.0 (2.5)	28	126	30	62	55	73	20-224	20	22	199	70 Nm	8600523
		M20 x 1.5								20x1.5					
		M22								22	24				
		3/4"-10UNC								3/4"	21				
	VIP 10 So-PP-S-3.5t (4.0)	M24	3.5 (4.0)	36	150	35	81	70	91	24-255	24	26	241	150 Nm	8600524
		M24 x 1.5								24x1.5					
		1"-8UNC								1"	28				
		M27								27	30			200 Nm	
	VIP 13 So-PP-S-5.0t (6.7)	M30	5.0 (6.7)	37	174	40	99	85	108	30-330	30	33	282	225 Nm	8600525
		M30 x 2								30x2					
1 1/4"-8UNC		1 1/4"-8UNC													
1 1/4"-7UNC		1 1/4"													
 Sonder-PowerPoint-B (ring)	VIP 4 So-PP-B-0.6t (0.63)	M12	0.6 (0.63)	9	65	35	42	36	47	12-140	12	13.5	112	10 Nm	8600560
		M12 x 1.5								12x1.5					
		1/2"-13UNC								1/2"	14				
	VIP 6 So-PP-B-1.0t (1.5)	M14	1.0 (1.5)	11	65	35	48	41	58	14-160	14	15.5	123	25 Nm	8600561
		M14 x 1.5								14x1.5					
	VIP 6 So-PP-B-1.3t (1.5)	M16	1.3 (1.5)	11	65	35	48	41	58	16-180	16	17.5	123	30 Nm	8600562
		M16 x 1.5								16x1.5					
		5/8"-11UNC								5/8"					
	VIP 8 So-PP-B-2.0t (2.5)	M20	2.0 (2.5)	13	75	40	62	55	73	20-224	20	22	148	70 Nm	8600563
		M20 x 1.5								20x1.5					
		M22								22	24				
		3/4"-10UNC								3/4"	21				
	VIP 10 So-PP-B-3.5t (4.0)	M24	3.5 (4.0)	16	95	45	81	70	91	24-255	24	26	186	150 Nm	8600564
		M24 x 1.5								24x1.5					
		1"-8UNC								1"	28				
		M27								27	30			200 Nm	
	VIP 13 So-PP-B-5.0t (6.7)	M30	5.0 (6.7)	21	130	60	99	85	108	30-330	30	33	238	225 Nm	8600565
		M30 x 2								30x2					
1 1/4"-8UNC		1 1/4"-8UNC													
1 1/4"-7UNC		1 1/4"													
 Sonder-PowerPoint-VIP (chain connection)	VIP 4 So-PP-VIP4-0.6t (0.63)	M12	0.6 (0.63)	4	-	-	42	36	47	12-140	12	13.5	47	10 Nm	8600320
		M12 x 1.5								12x1.5					
		1/2"-13UNC								1/2"	14				
	VIP 6 So-PP-VIP6-1.0t (1.5)	M14	1.0 (1.5)	6	-	-	48	41	58	14-160	14	15.5	58	25 Nm	8600326
		M14 x 1.5								14x1.5					
	VIP 6 So-PP-VIP6-1.3t (1.5)	M16	1.3 (1.5)	6	-	-	48	41	58	16-180	16	17.5	58	30 Nm	8600321
		M16 x 1.5								16x1.5					
		5/8"-11UNC								5/8"					
	VIP 8 So-PP-VIP8-2.0t (2.5)	M20	2.0 (2.5)	8	-	-	62	55	73	20-224	20	22	73	70 Nm	8600322
		M20 x 1.5								20x1.5					
		M22								22	24				
		3/4"-10UNC								3/4"	21				
	VIP 10 So-PP-VIP10-3.5t (4.0)	M24	3.5 (4.0)	10	-	-	81	70	91	24-255	24	26	91	150 Nm	8600323
		M24 x 1.5								24x1.5					
		1"-8UNC								1"	28				
		M27								27	30			200 Nm	
	VIP 13 So-PP-VIP13-5.0t (6.7)	M30	5.0 (6.7)	13	-	-	99	85	108	30-330	30	33	108	225 Nm	8600324
		M30 x 2								30x2					
1 1/4"-8UNC		1 1/4"-8UNC													
1 1/4"-7UNC		1 1/4"													

Table 1: Dimensioning

() higher WLL at axial (vertical) direction of load

Subject to technical alterations

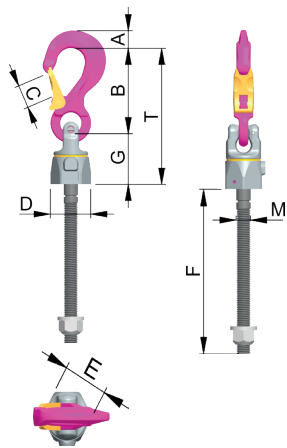

So-PP-S/PP-S

0.6 t, 1.0 t, 1.3 t, 2.0 t, 3.5 t, 5.0 t
and Vario length variants

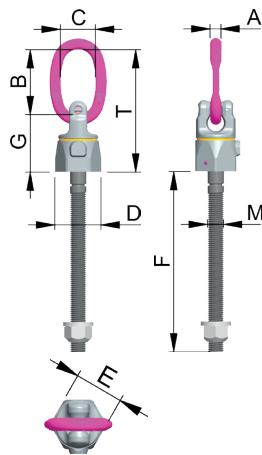

So-PP-B/PP-B

0.6 t, 1.0 t, 1.3 t, 2.0 t, 3.5 t, 5.0 t
and Vario length variants

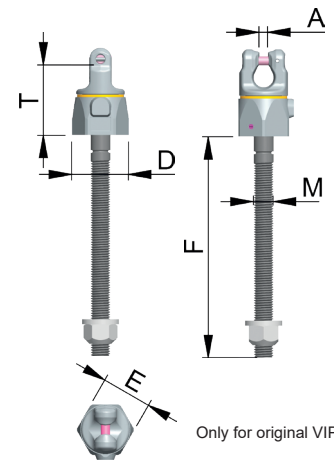

So-PP-VIP/PP-VIP

0.6 t, 1.0 t, 1.3 t, 2.0 t, 3.5 t, 5.0 t
and Vario length variants

Method of lift										
Method of lift										
Number of legs	1	1	2	2	2	2	2	3 & 4	3 & 4	3 & 4
Angle of inclination β	0°	90°	0°	90°	0-45°	45-60°	unsymm.	0-45°	45-60°	unsymm.
Factor	1	1	2	2	1.4	1	1	2.1	1.5	1
Type	Max weight of load >G< for all PowerPoint types with different sling methods									
So-PP-... 0.6t (0.63) M12	0.63 t (1385 lbs)	0.6 t (1320 lbs)	1.26 t (2770 lbs)	1.2 t (2640 lbs)	0.84 t (1850 lbs)	0.6 t (1320 lbs)	0.6 t (1320 lbs)	1.26 t (2770 lbs)	0.9 t (1980 lbs)	0.6 t (1320 lbs)
So-PP-... 0.6t (0.63) M12x1.5										
So-PP-... 1/2"-13UNC										
So-PP-... 1.0t (1.5) M14	1.5 t (3300 lbs)	1.0 t (2200 lbs)	3.0 t (6600 lbs)	2.0 t (4400 lbs)	1.4 t (3080 lbs)	1.0 t (2200 lbs)	1.0 t (2200 lbs)	2.1 t (4650 lbs)	1.5 t (3300 lbs)	1.0 t (2200 lbs)
So-PP-... 1.0t (1.5) M14x1.5										
So-PP-... 1.3t (1.5) M16	1.5 t (3300 lbs)	1.3 t (2860 lbs)	3.0 t (6600 lbs)	2.6 t (5720 lbs)	1.82 t (4000 lbs)	1.3 t (2860 lbs)	1.3 t (2860 lbs)	2.73 t (6000 lbs)	1.95 t (4290 lbs)	1.3 t (2860 lbs)
So-PP-... 1.3t (1.5) M16x1.5										
So-PP-... 5/8"-11UNC										
So-PP-... 2.0t (2.5) M20	2.5 t (5500 lbs)	2.0 t (4400 lbs)	5.0 t (11000 lbs)	4.0 t (8800 lbs)	2.8 t (6160 lbs)	2.0 t (4400 lbs)	2.0 t (4400 lbs)	4.2 t (9240 lbs)	3.0 t (6600 lbs)	2.0 t (4400 lbs)
So-PP-... 2.0t (2.5) M20x1.5										
So-PP-... 2.0t (2.5) M22										
So-PP-... 3/4"-10UNC										
So-PP-... 3.5t (4.0) M24	4.0 t (8800 lbs)	3.5 t (7700 lbs)	8.0 t (17600 lbs)	7.0 t (15400 lbs)	4.9 t (10780 lbs)	3.5 t (7700 lbs)	3.5 t (7700 lbs)	7.35 t (16170 lbs)	5.25 t (11550 lbs)	3.5 t (7700 lbs)
So-PP-... 3.5t (4.0) M24x1.5										
So-PP-... 1"-8UNC										
So-PP-... 3.5t (4.0) M27										
So-PP-... 5.0t (6.7) M30	6.7 t (14750 lbs)	5.0 t (11000 lbs)	13.4 t (29500 lbs)	10.0 t (22000 lbs)	7.0 t (15400 lbs)	5.0 t (11000 lbs)	5.0 t (11000 lbs)	10.5 t (23100 lbs)	7.5 t (16500 lbs)	5.0 t (11000 lbs)
So-PP-... 5.0t (6.7) M30x2										
So-PP-... 1 1/4"-8UN										
So-PP-... 1 1/4"-7UNC										

table 2: WLL overview