

NITROGAS

GASSPRING CATALOGUE
CUSTOMIZED FOR



NITROGAS is a global company that has a worldwide presence through its own network of subsidiaries and extensive distributor network.

SUBSIDIARIES

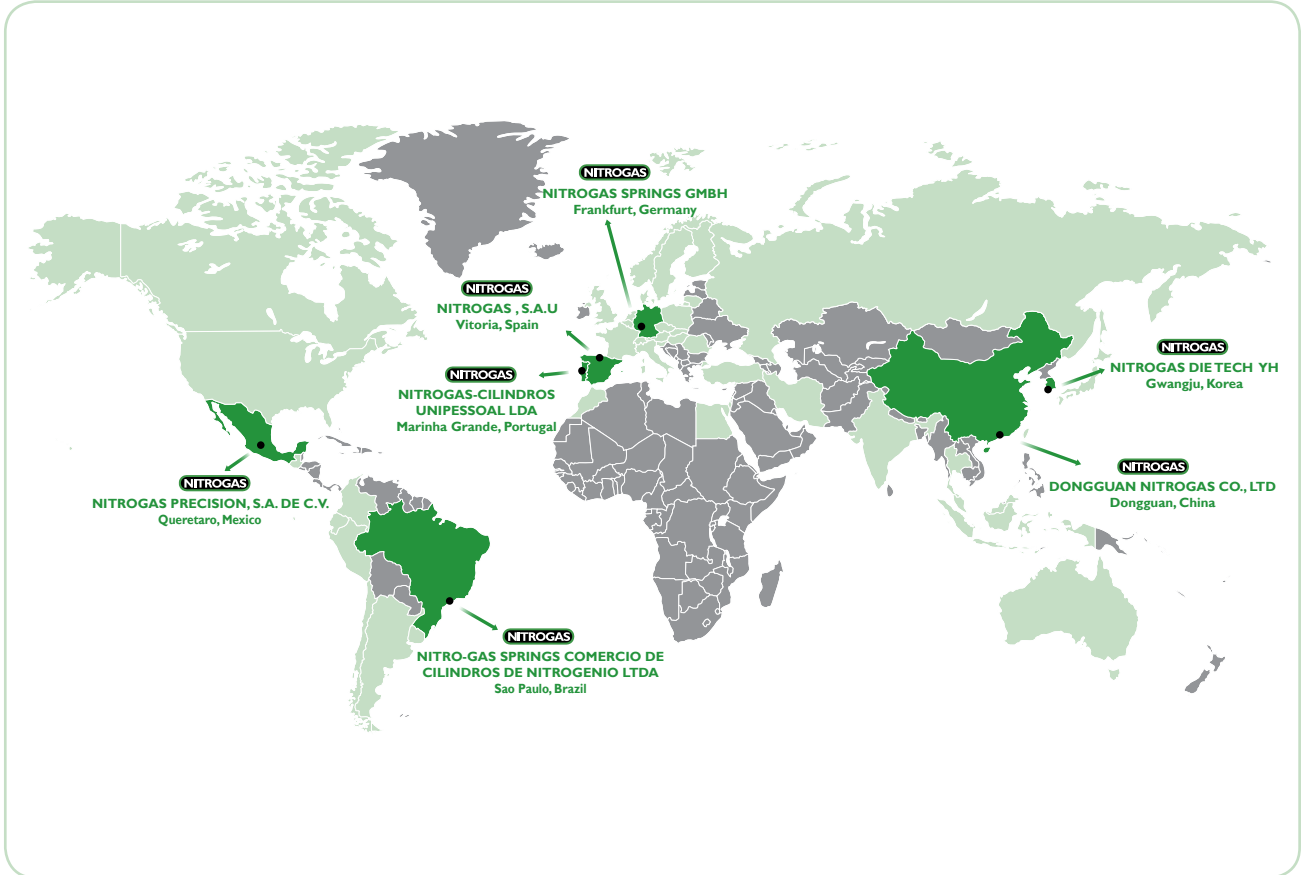

DISTRIBUTORS

WESTERN EUROPE

Austria	Italy	Sweden
Denmark	Netherlands	Switzerland
Finland	Norway	United Kingdom
France	Portugal	
Germany	Spain	

EASTERN EUROPE

Slovakia	Hungary
Slovenia	Czech Republic
Lithuania	Poland
Romania	Turkey
Russia	

AMERICA

Argentina	Guatemala
Brazil	Mexico
Canada	Peru
Chile	Uruguay
Colombia	USA
Ecuador	

ASIA-OCEANIA

Australia	Japan
China	Korea
India	Malaysia
Indonesia	Russia
Iran	Taiwan
Israel	Thailand

AFRICA

Morocco
South Africa

Our customers can learn more about the nearest contact on our website:

www.nitrogas.com/es/Worldwide.aspx

TECHNICAL INFORMATION

2

Why Nitrogas?	2
NTC	3
Quality and Safety	4
Total Security	5
Technical Features	6
Safety Standards	8
Specifications for Installation and Use	10
Maintenance Recomendations	12

GAS SPRINGS

14

Gas Spring Selection Guide	14
MICRO	17
Z-50	18
R-100	20
R-200	22
ISO	25
CN-150	26
CN-250	28
CN-500	30
G-750	32
G-1500	34
G-3000	36
G-5000	38
CN-7500	40
CN-10000	42
LOW PROFILE - HIGH FORCE	45
KP-150	46
KP-350	48
KP-500	50
KP-750	52
KP-1000	54
KP-1500	56
KP-2400	58
KP-4200	60
KP-6600	62
KP-9500	64

ACCESSORIES

67

Gas link system	67
Complements	79



BEST GAS SPRING IN THE MARKET

NITROGAS's gas springs offer the world's most advanced technology, guaranteeing longer gas spring life than other products on the market.

NITROGAS offers customers products that meet any test of approval, confirming the longest life of our gas springs.



25 YEARS OF EXPERIENCE SPEAKS FOR ITSELF



NITROGAS was founded in Vitoria (Spain) in 1988 and has become one of the most important manufacturers of gas cylinders.

For 25 years we have developed this technology.

Today, NITROGAS has his wholly owned subsidiaries in Germany, Portugal, China, Korea, Mexico and Brazil besides its dealer network.

ENGINEERS TO THE SERVICE OF TECHNICAL DEPARTMENTS

NITROGAS ensures maximum technical support to its customers, with prompt response to any application assistance or questions related to their products.



TECHNOLOGICAL PARTNERS – SPECIFIC SOLUTIONS



NITROGAS created the NITROGAS TECHNOLOGY CENTER (NTC), bringing together a group of engineers and technicians to concentrate on the R & D services the company gives to customers with specific projects that may require special solutions or need higher performance than other standard products on the market.

WORLD PRESENCE – PLANT SUPPORT (STOCK, REPAIRS...)

NITROGAS analyzes and diagnoses with its customers any product and service needs required in each customers' facility, formulating a response that meets customer expectations.

NITROGAS structure allows reaching any market in the world.





NITROGAS is a company strongly committed to research and innovation. It has the largest Research and Knowledge Center in the world concerning gas springs: NITROGAS TECHNOLOGY CENTER.

Here a team of experienced engineers investigate and test the latest improvements and technologies related to the development of gas springs. As a result of hard work, several worldwide patents were obtained, and allow NITROGAS to remain leader in the development of new products, offering high tech solutions. NITROGAS also provides solutions to special request, or response to any question, problem or need of our customer.

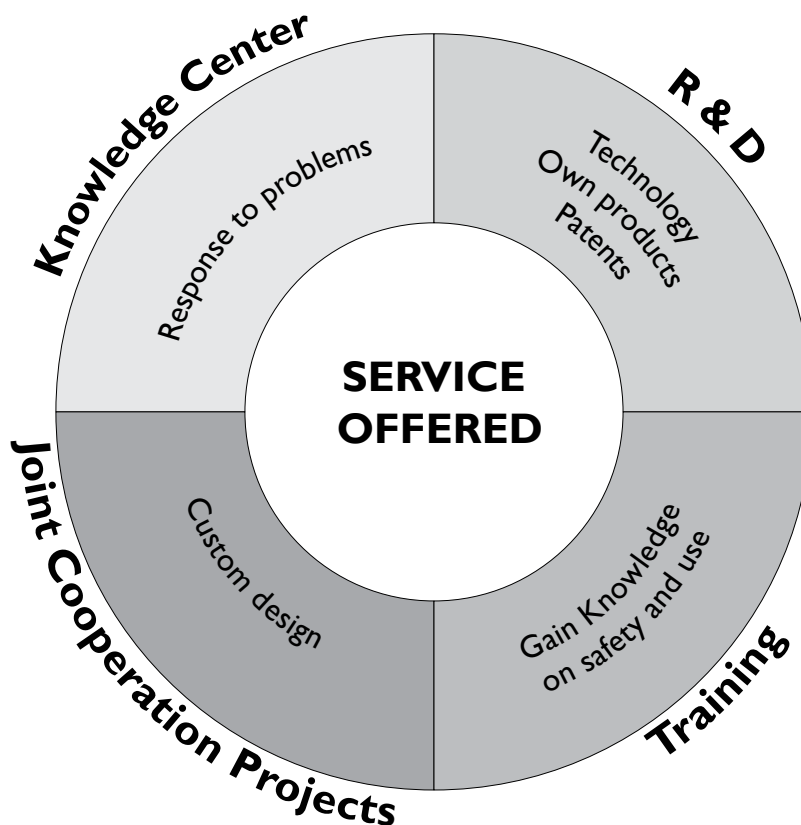

Quality and Safety

Safety is a top priority for NITROGAS and we strongly believe that gas springs for metal stamping should meet some basic safety requirements.

Having always in mind our mission to satisfy our customers, NITROGAS was awarded in 1998 with the certification by Bureau Veritas in accordance with the requirement of the management system standards of ISO 9001:2000 Norm. This certification has been renewed in 2011 and is valid until 2014.



PED

NITROGAS is also certified by the Pressure Equipment Directive 2014/68/EU Directive that regulates the proper manufacturing of pressure equipment.

Automotive Standards

Supplementary to the standards mentioned above, NITROGAS products also meet other automotive standards. If any standard-icon is showed, the gas springs's body and rod are designed to keep the dimensions that are established in this standard.



ISO : ISO 11901

- ISO 11901-1 - Tools for pressing. Gas Springs. General specifications.
- ISO 11901-2 - Tools for pressing. Gas Springs. Specification of accessories.
- ISO 11901-3 - Tools for pressing. Gas Springs. Gas spring with increased spring force and compact built height.
- ISO 11901-4 - Tools for pressing. Gas Springs. Gas springs with increased spring force and same built height.



VDI : Verein Deutscher Ingenieure

- VDI 3003 - Nitrogen gas springs in large stamping dies and mounting versions.
- VDI 3004 - Forcing pins with helical compression springs or nitrogen gas springs.

CNOMO
EM24.54.700

CNOMO : Renault Group

CNOMO EM24.54.700 - Gas springs, pneumatic springs for press tooling.

PSA
E24.54.815.G

PSA : Peugeot - Citroën Group

PSA E24.54.815.G - Gas springs and accessories.

SMS DNH
3203N

TOYOTA

SMS DNH 3203N - Toyota standard.

Total Security

NITROGAS want to offer the safest product with the longest life. Below there are some of our improvements related to the design, use and management of the gas spring that would make the maintenance work easier.

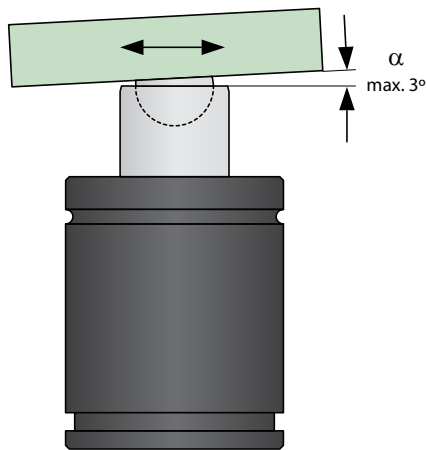

ESK System PATENTED

Design for compensate unbalanced forces and increase gas springs life. This system allows up to two degrees of side load and unlike other balanced systems, the ESK system maintains the rod in vertical position.

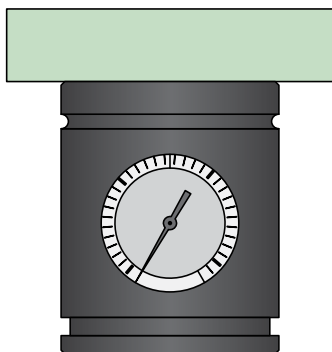

Blow Out Protection System

Safety system that allows a controlled nitrogen gas discharge in case of overcome working limits.

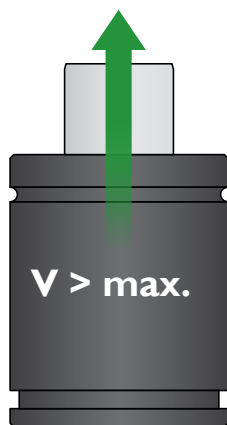

Excessive Return Speed Lifeguard

The new and safer design of the gas springs avoids the rupture in case of an excessively rapid return stroke.

Technical Features

NITROGAS gas springs can be divided into Piston Rod Sealed gas springs or Bore Sealed gas springs depending on the type of seal and where it is located. The force of each gas spring depends on the nitrogen charging pressure and the working surface.

$$F \text{ (daN)} = P \text{ (bar)} \times S \text{ (mm}^2\text{)} / 100 \quad \text{where} \quad S = \pi \times d^2 / 4$$

Piston Rod Sealed gas springs

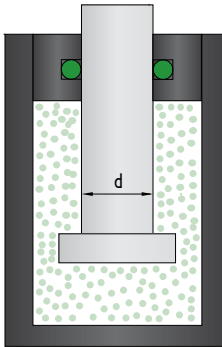

Piston rod gas springs suit a wide range of needs due to the high variety on their design.

To calculate the force of a piston rod sealed gas spring the diameter to take into account is the diameter of the rod.

Practical example using G-1500 gas spring:

$$\begin{aligned} d &= 36 \text{ mm} \\ P &= 150 \text{ bar} \\ S &= \pi \times 36^2 / 4 = 1018 \text{ mm}^2 \\ F &= 150 \times 1018 / 100 = 1527 \text{ daN} \end{aligned}$$

Bore Sealed gas springs

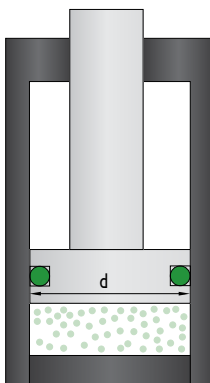

Bore sealed gas springs are ideal for small movements and very strong forces with a maximum contact pressure.

To calculate the force of a bore sealed gas spring the diameter to take into account is the diameter of the piston.

Practical example using T-1800 gas spring:

$$\begin{aligned} d &= 40 \text{ mm} \\ P &= 145 \text{ bar} \\ S &= \pi \times 40^2 / 4 = 1257 \text{ mm}^2 \\ F &= 145 \times 1257 / 100 = 1822 \text{ daN} \end{aligned}$$



Safety Standards

The gas springs contain high pressure gas. The rules detailed below are mandatory.



Any unauthorized operation performed, or improper use can cause serious material or personal injury. If there is any suspicion of damage to the gas spring, immediately remove it.

NITROGAS is not responsible for personal injury and damage that may happen because of violation of such security rules.

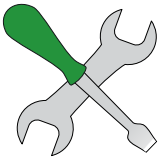

- 1 Maintenance must be performed exclusively by personal that has been trained and certified by NITROGAS. Any improper handling could cause serious safety hazards or limit the lifetime of the gas springs.
Before any repair, discharge the pressure and ensure that the rod is completely within the body.

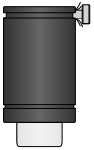

- 2 During discharge of the gas spring, orientate the gas flow in the opposite direction to the operator and position the discharge point as high as possible.
We recommend the use of eyewear.



- 3 Gas springs must only be charged with commercial nitrogen.
The maximum charge pressure (at 20 °C) is marked on each gas spring. Do not exceed the maximum charge pressure without the prior written consent of NITROGAS.

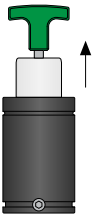

- 4 Before loading any gas spring, ensure that the piston rod is in its most extended position and the safety ring (in case any) is perfectly located in the housing.

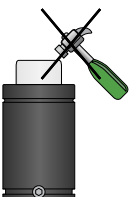

- 5 To test the force of a gas spring, there are specific tools for measurement to be used. Never hit on the rod to see if the gas spring is under pressure.



- 6 We recommend a regular visual inspection of the gas springs.
If a gas spring has damage to its structure, discharge the pressure prior to review.

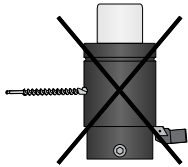

- 7 Any secondary operation (including grinding, machining, or welding) on any part of the gas spring is completely forbidden.
The risks increase if operations are performed with a loaded gas spring.

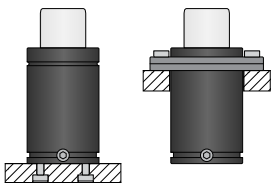

- 8 Gas springs must only be installed in the tool in the ways described in the specification sheet for each model.
The gas springs shall be securely held in place by the thread of the bottom of the body or by fastening accessories NITROGAS offers in each model.

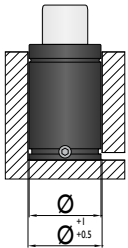

- 9 In the case of accommodating the gas spring in a pocket drilled in the tool, the body must be adjusted to the hole to prevent from pitching.
If the gas spring is housed in a pocket that can be flooded, please allow for drainage to facilitate the outlet of fluids.

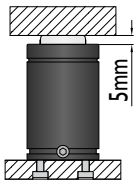

- 10 Avoid using the last 5 mm of the gas spring stroke to prevent possible over-stroke caused by changes or errors in the tool.
An excessive stroke can have serious and obvious security risks that can cause permanent damage to the gas spring.

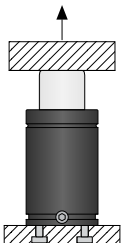

- 11 Prevent the sudden or uncontrolled rod output. Do not exceed the maximum speed specified in the file for each model.

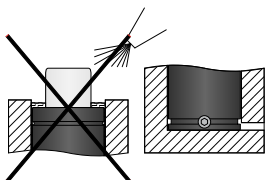

- 12 Protect the gas springs from direct contact with liquids or solids contaminations. If the gas cylinder is housed in a pocket that can be flooded, include drains to facilitate any outlet of fluids. In the case of fluids, the body should protrude 5 mm from surface to prevent fluids accumulation.

Specifications for Installation and Use



For proper operation, gas springs must be installed following the specifications for installation and use described below.

NITROGAS is not liable for damages or premature wear caused to gas springs, due to failure to comply with these specifications for installation and use.

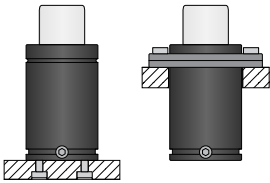

- 1 Install gas springs in the tool only in the ways described in the specification sheet for each model.

Gas springs must be securely fastened by the threads of the bottom of the body or by fastening the accessories NITROGAS offers for each model.

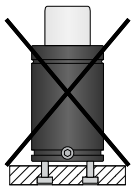

- 2 Check that the length of the fastening screw used is adequate so that the settlement of the gas spring is always on its base.

Tighten the clamping screws holding the base of the cylinder to the recommended torque:

M6 = 10Nm, M8 = 24Nm, M10 = 45Nm, M12 = 80Nm.

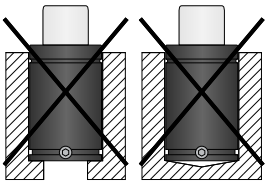

- 3 The base of the gas spring must rest on a plane support. Inadequate housing can damage the gas spring or reduce its life.

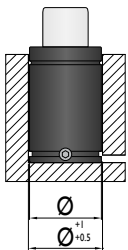

- 4 In case of accommodating the gas spring in a drilled pocket in the tool, the body must be adjusted to the hole to prevent from pitching.

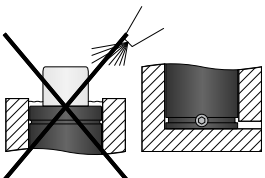

- 5 Protect gas springs from liquid or solid contamination. If the gas spring is housed in a pocket that can be flooded, include drains to facilitate any fluid outlet. In the case of fluids, the body should protrude 5 mm from surface to prevent fluids accumulation.

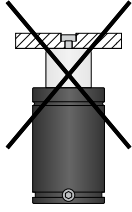

- 6 Do not use the threaded holes in the rod end to fix the gas spring to the tool.
This hole is only intended for maintenance. Do not use for transport operations of gas springs.

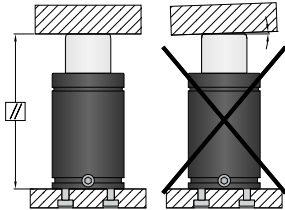

- 7 Ensure parallelism between the surface of the gas spring and the rod pushing surface to prevent the occurrence of lateral forces. The hardness of the contact surface should be sufficient. Ensure full contact on the bearing surface of the rod.

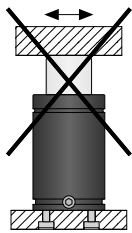

- 8 Avoid any lateral displacement of the gas spring while running. Give special attention to any vibrations during movement of the rod.

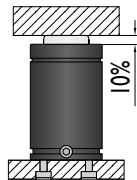

- 9 It is recommended to provide a reserve of travel at least 10% of the nominal stroke. The recommended reserve of travel for each gas spring is indicated in the specification sheet for each model.

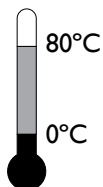

- 10 The operating temperature of the gas springs is between 0 °C and 80 °C. Upon request NITROGAS can supply gas springs supporting temperatures between - 20 °C and 180 °C.

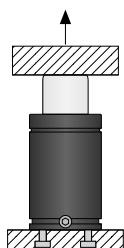

- 11 Prevent the sudden or uncontrolled rod output. Do not exceed the maximum speed specified in the file for each model.

Maintenance Recommendations



Maintenance must be carried out exclusively by personal that has been trained and certified by NITROGAS. Any improper handling could cause serious safety hazards or limit the lifetime of the gas springs.



- 1 Before any repair, discharge entirely the pressure and ensure that the rod is completely within the body.

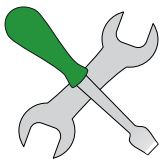

- 2 We recommend a regular visual inspection of the gas springs. If a cylinder has damage to its structure, fully discharge the pressure prior to review.



- 3 During unloading of the gas spring, direct the flow of gas away from the operator and position the discharge point as high as possible. We recommend using safety glasses.



- 4 Never throw away the gas spring without having properly discharged the pressure.



- 5 Gas springs must be loaded with commercial nitrogen. The maximum loading pressure (at 20 °C) is marked on each gas spring. Do not exceed the maximum charge pressure without the prior written consent of NITROGAS.

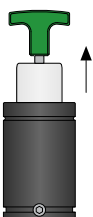

- 6 Before loading any gas spring, make sure that the rod is in its most extended position and the safety ring (in case any) is perfectly located in the housing.



- 7 To test the strength of a specific cylinder there are specific tools for measuring the force. Never hit the rod to see if the gas spring is under pressure.

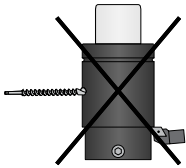

- 8 To ensure correct operation of the gas spring, the surfaces of the rod and body of the gas spring must remain free of blows, scratches, or any type of deformation.
The secondary operations of any part of the gas spring (including grinding, machining, welding, etc.) are completely forbidden.









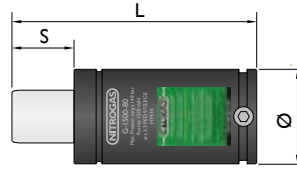

- 9 Protect gas springs during transportation. Protect gas springs from hitting each other; protect them from oxidation in the case of maritime transport.



Gas Spring Selection Guide







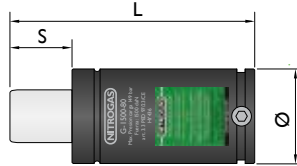



Gas spring family

Force	MICRO	LOW PROFILE HIGH FORCE	ISO	Model	max F0	Ø mm	S mm	L mm		Linkable	Page
100 daN				Z-50	13 - 50	12	7 - 125	2xS + 42	No	No	18
				R-100	30 - 90	19	7 - 125	2xS + 42	No	No	20
150 - 200 daN				KP-150	150	19	7 - 125	2xS + 30	No	No	46
				R-200	50 - 200	25	10 - 125	2xS + 42	No	No	22
				CN-150	150	32	10 - 125	2xS + 50	No	No	26
250 - 300 daN				CN-250	265	38	10 - 125	2xS + 50	No	M6	28
320 - 450 daN				KP-350	360	32	10 - 125	2xS + 30	No	M6	48
500 - 600 daN				KP-500	470	38	10 - 125	2xS + 30	No	M6	50
				CN-500	470	45	12.7 - 160	2xS + 85	No	G1/8"	30
750 daN				KP-750	740	45	10 - 125	2xS + 32	Yes	M6	52
				G-750	740	50	12.7 - 300	2xS + 95	Yes	G1/8"	32
1000 daN				KP-1000	920	50	13 - 125	2xS + 38	Yes	M6	54



Gas spring family

Force	LOW PROFILE HIGH FORCE	ISO	Model	max F0	Ø mm	S mm	L mm		Linkable	Page
1500 daN	 KP-1500	 G-1500	KP-1500	1500	63	13 - 125	2xS + 44	Yes	M6	56
			G-1500	1500	75	25 - 300	2xS + 110	Yes	G1/8"	34
2500 daN	 KP-2400		KP-2400	2400	75	16 - 125	2xS + 45	Yes	M6	58
3000 daN		 G-3000	G-3000	3000	95	25 - 300	2xS + 120	Yes	G1/8"	36
4000 daN	 KP-4200		KP-4200	4200	95	16 - 125	2xS + 58	Yes	G1/8"	60
5000 daN		 G-5000	G-5000	5000	120	25 - 300	2xS + 140	Yes	G1/8"	38
6500 daN	 KP-6600		KP-6600	6600	120	16 - 125	2xS + 68	Yes	G1/8"	62
7500 daN		 CN-7500	CN-7500	7500	150	25 - 300	2xS + 155	Yes	G1/8"	40
10000 daN	 KP-9500	 CN-10000	KP-9500	9500	150	19 - 125	2xS + 78	Yes	G1/8"	64
			CN-10000	10600	195	25 - 300	2xS + 160	Yes	G1/8"	42



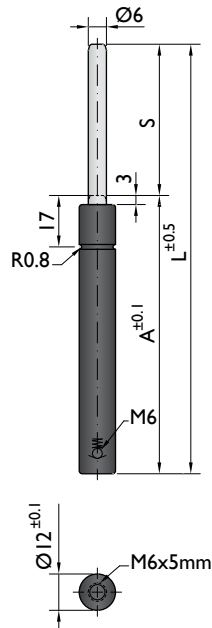

Force / Pressure

		daN	bar (20°C)
V	GREEN	13	45
Z	BLUE	25	90
R	RED	38	135
A	YELLOW	50	180

* maximum force if not specified

Max. strokes / minutes

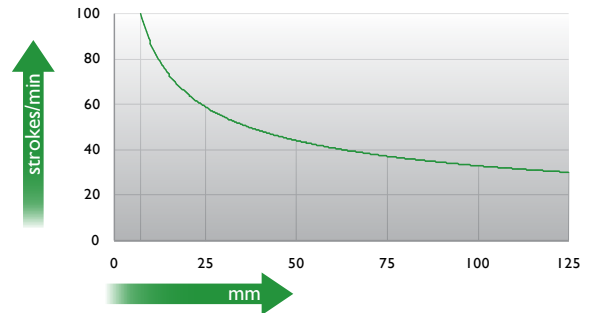

Ordering example: 4 x GGS M 00050 080 - V

Order No.	NITROGAS	S mm	L mm	A mm	F ₀ daN (20°C, 180 bar)	F daN		kg
GGG M 00050 010	Z-50-10	10	62	52	50	60	No	0.03
GGG M 00050 015	Z-50-15	15	72	57		70	No	0.03
GGG M 00050 025	Z-50-25	25	92	67		70	No	0.04
GGG M 00050 050	Z-50-50	50	142	92		70	No	0.05
GGG M 00050 080	Z-50-80	80	205	125		80	No	0.07
GGG M 00050 125	Z-50-125	125	295	170		80	No	0.09



Pressure medium	N ₂	Working temperature	0-80°C	Min. security stroke	10%
Max. Charging pressure	180 bar	Temperature related force increase	+0.34%/°C	Repair Kit	Non-repairable
Min. Charging pressure	25 bar	Max. working speed	1.6 m/s	Linkable	No

Mounting possibilities



The gas spring must be fixed by flanges or by bottom with screws and lock washer.

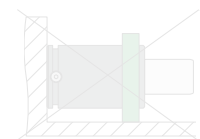
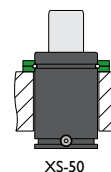
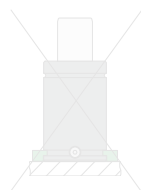
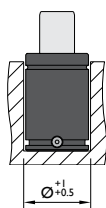
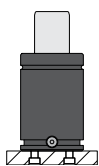

Flanges

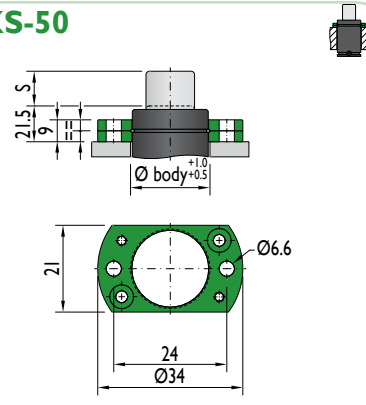
XS-50 		





*The new cylinder will be supplied when the stock runs out.

NEW MODEL*

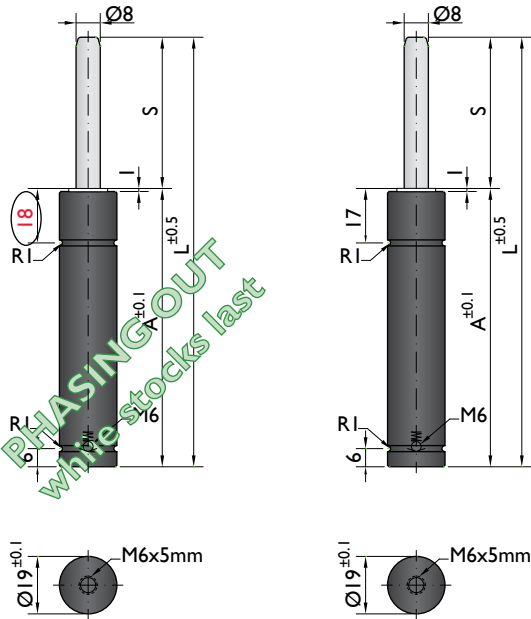

Force / Pressure

		daN	bar (20°C)
V	GREEN	30	60
Z	BLUE	50	100
R	RED	70	140
A	YELLOW	90	180

* maximum force if not specified

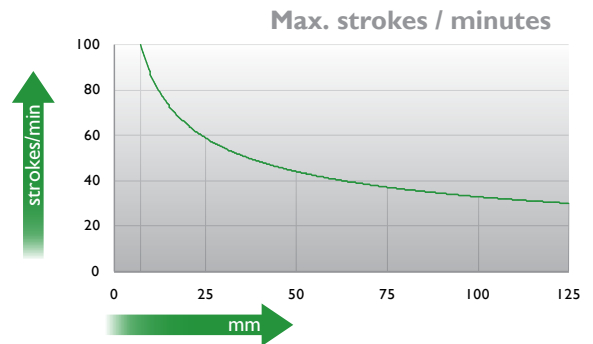

Ordering example: 4 x GGS M 00090 080 - R

Order No.	NITROGAS	S mm	L mm	A mm	F ₀ daN (20°C, 180 bar)	F daN		kg
GGG M 00090 010	R-100-10	10	62	52	90	120	No	0.08
GGG M 00090 015	R-100-15	15	72	57		120	No	0.08
GGG M 00090 025	R-100-25	25	92	67		120	No	0.08
GGG M 00090 050	R-100-50	50	142	92		120	No	0.12
GGG M 00090 080	R-100-80	80	205	125		120	No	0.14
GGG M 00090 125	R-100-125	125	295	170		120	No	0.20



Pressure medium	N ₂	Working temperature	0-80°C	Min. security stroke	10%
Max. Charging pressure	180 bar	Temperature related force increase	+0.34%/°C	Repair Kit	Non-repairable
Min. Charging pressure	25 bar	Max. working speed	1.6 m/s	Linkable	No

Mounting possibilities



The gas spring must be fixed by flanges or by bottom with screws and lock washer.

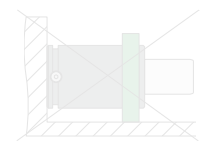
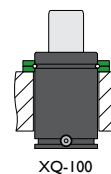
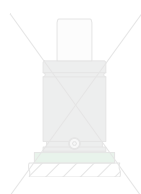
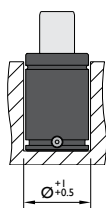
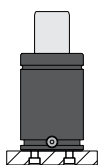

Flanges

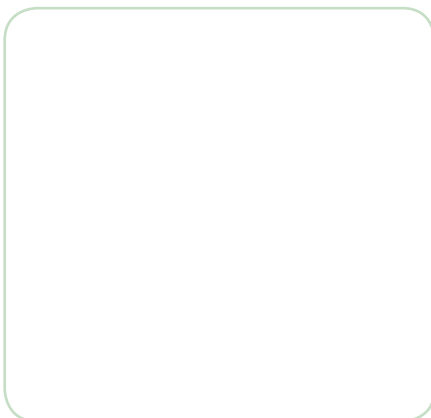
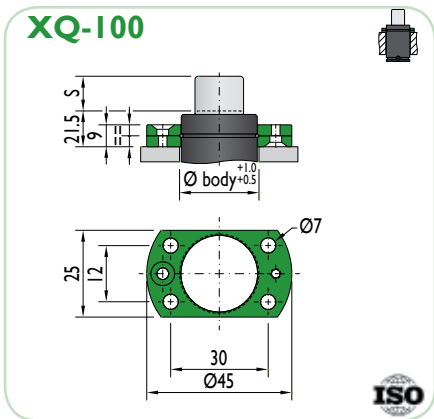

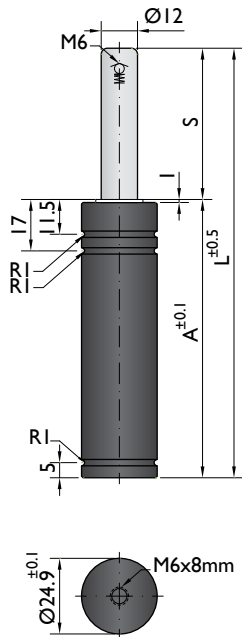

Force / Pressure

		daN	bar (20°C)
V	GREEN	50	45
Z	BLUE	100	90
R	RED	150	135
A	YELLOW	200	180

* maximum force if not specified

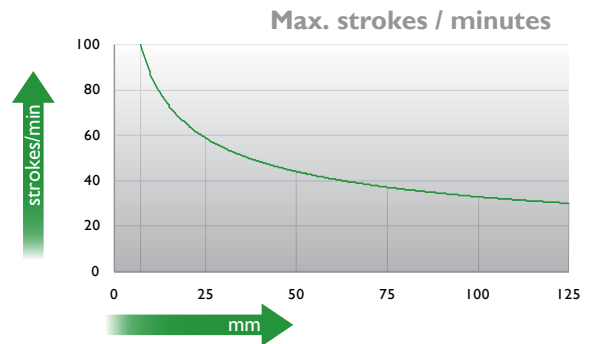

Ordering example: 4 x GGS M 00200 080 - Z

Order No.	NITROGAS	S mm	L mm	A mm	F ₀ daN (20°C, 180 bar)	F daN (20°C, 180 bar)	kg
GGG M 00200 010	R-200-10	10	62	52	200	260	0.14
GGG M 00200 015	R-200-15	15	72	57		260	0.15
GGG M 00200 025	R-200-25	25	92	67		270	0.17
GGG M 00200 050	R-200-50	50	142	92		280	0.22
GGG M 00200 080	R-200-80	80	205	125		290	0.28
GGG M 00200 125	R-200-125	125	295	170		290	0.37



Pressure medium	N ₂	Working temperature	0-80°C	Min. security stroke	10%
Max. Charging pressure	180 bar	Temperature related force increase	+0.34%/°C	Repair Kit	KIT R-200
Min. Charging pressure	25 bar	Max. working speed	1.6 m/s	Linkable	No

Mounting possibilities



The gas spring must be fixed by flanges or by bottom with screws and lock washer.

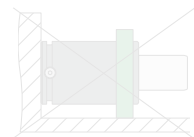
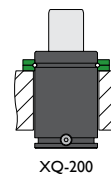
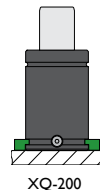
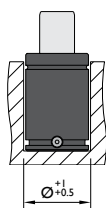
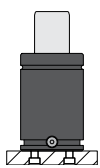

Flanges

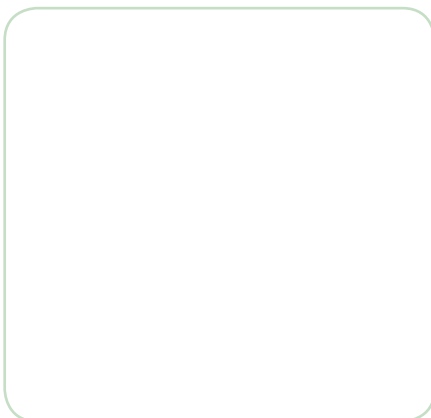
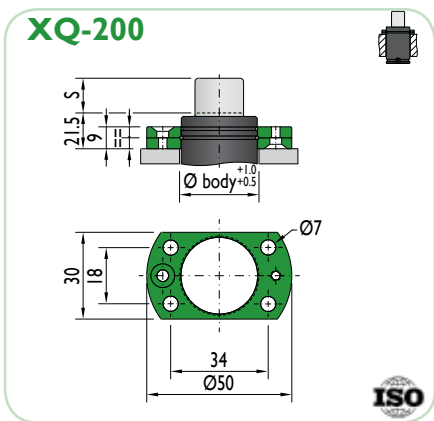
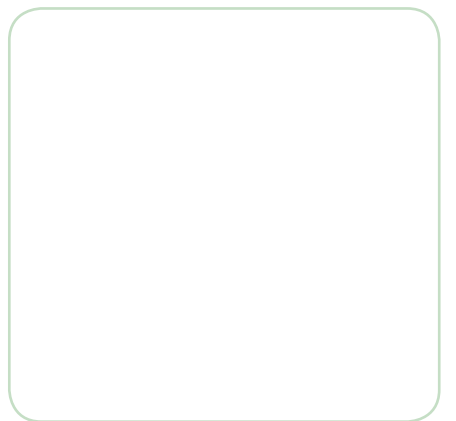
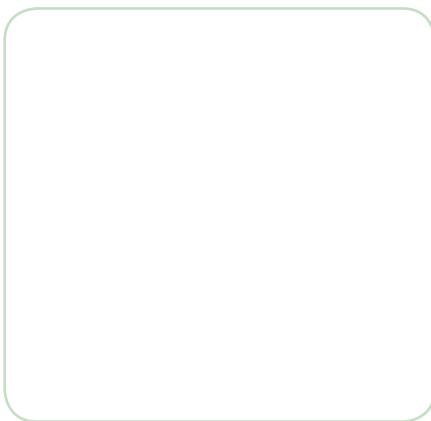
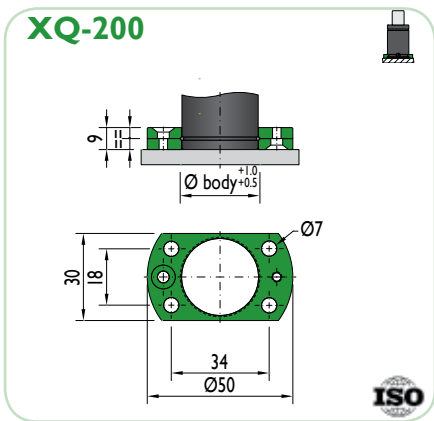

ISO Gas Springs

Designed to keep the dimensions established in the ISO 11901-I standard. CN and G series available.

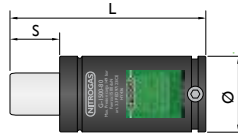

CN	F ₀ daN	Ø mm	L mm	STROKE																							
				6	7	10	12	13	15	16	19	20	25	30	32	38	40	50	60	63	75	80	100	125	160	200	250
CN-150	150	32	2xS+50			*		*							*					*		*		*			
CN-250	265	38	2xS+50			*		*							*					*		*		*			
CN-500	470	45	2xS+85												*					*		*		*			
CN-7500	7500	150	2xS+155												*					*		*		*		*	
CN-10000	10600	195	2xS+160																	*		*		*		*	

G	F ₀ daN	Ø mm	L mm	STROKE																							
				6	7	10	12	13	15	16	19	20	25	30	32	38	40	50	60	63	75	80	100	125	160	200	250
G-750	740	50	2xS+95													*				*		*		*		*	
G-1500	1500	75	2xS+110													*				*		*		*		*	
G-3000	3000	95	2xS+120													*				*		*		*		*	
G-5000	5000	120	2xS+140													*				*		*		*		*	





CNOMO
EM24.54.700

PSA
E24.54.815.G

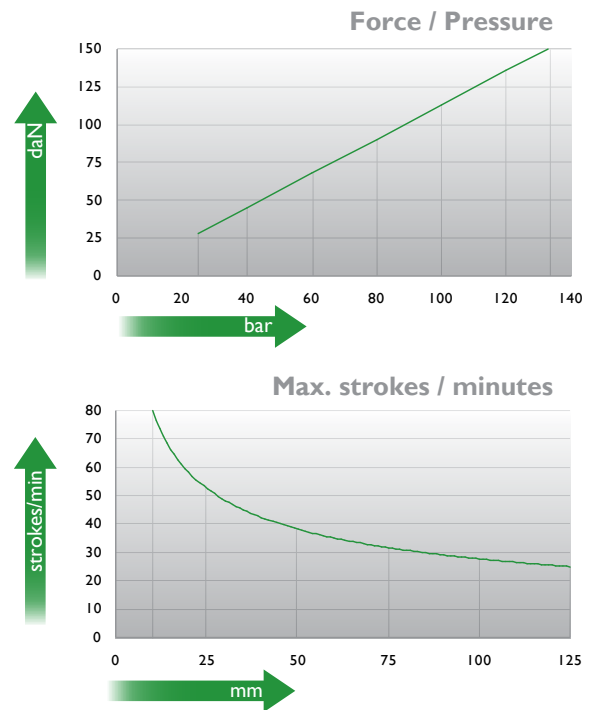
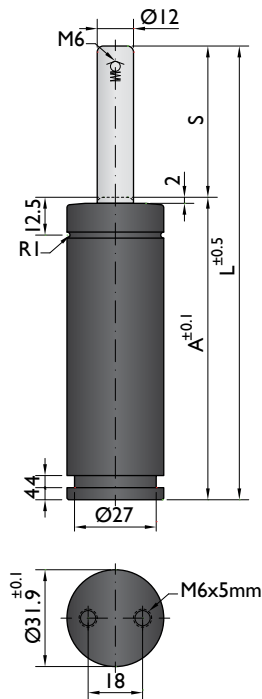

Ordering example: 4 x GGS I 00150 080

Order No.	NITROGAS	S mm	L mm	A mm	F ₀ daN	F daN		kg
					(20°C, 135 bar)			
GGS I 00150 010	CN-150-10	10	70	60	150	170	No	0.27
GGS I 00150 013	CN-150-13	12.7	75.4	62.7		180	No	0.28
GGS I 00150 025	CN-150-25	25	100	75		180	No	0.33
GGS I 00150 050	CN-150-50	50	150	100		190	No	0.43
GGS I 00150 080	CN-150-80	80	210	130		200	No	0.56
GGS I 00150 125	CN-150-125	125	300	175		200	No	0.73



Pressure medium	N ₂	Working temperature	0-80°C	Min. security stroke	10%
Max. Charging pressure	135 bar	Temperature related force increase	+0.34%/°C	Repair Kit	KIT CN-150
Min. Charging pressure	25 bar	Max. working speed	1.6 m/s	Linkable	No

Mounting possibilities



The gas spring must be fixed by flanges or by bottom with screws and lock washer.

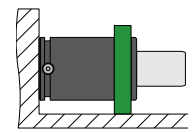
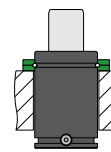
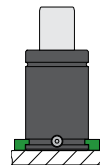
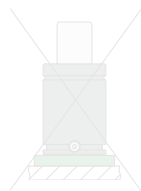
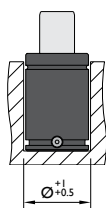
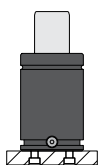

Flange must not support spring's force

Flanges

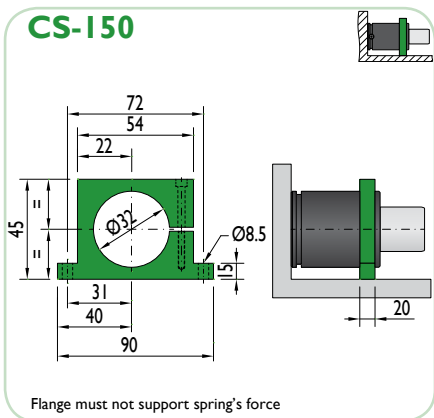
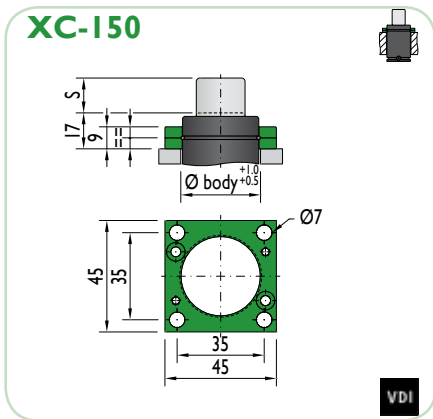
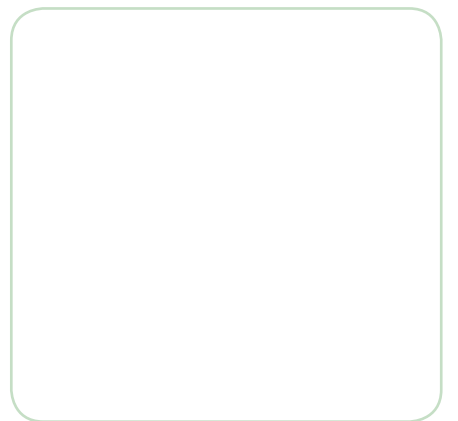
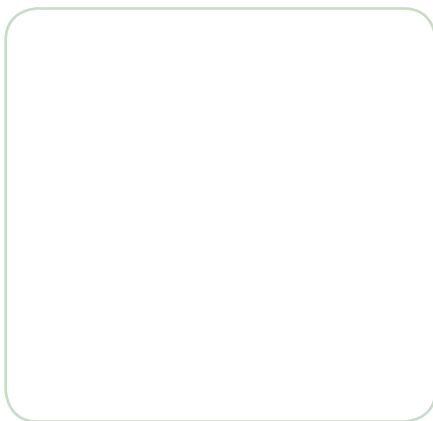
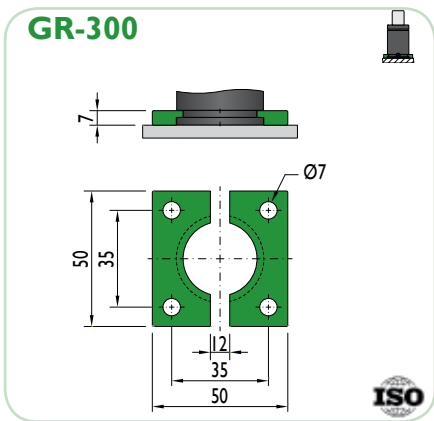



CNOMO
EM24.54.700

PSA
E24.54.815.G

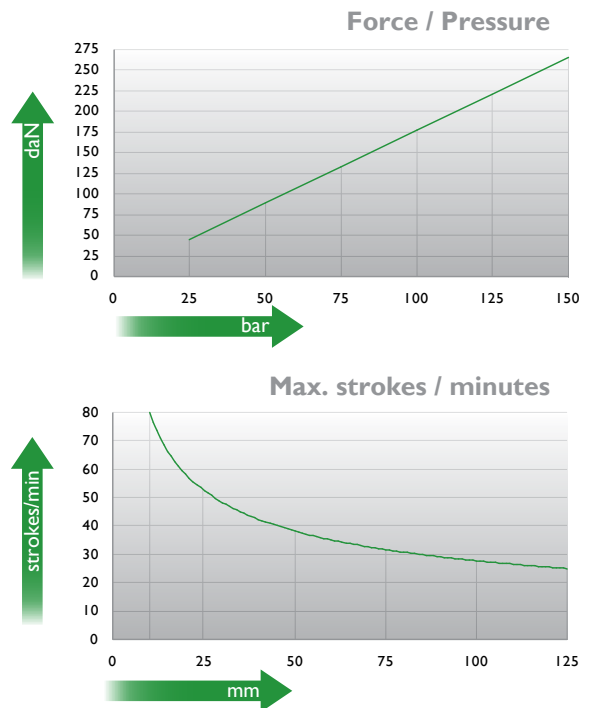
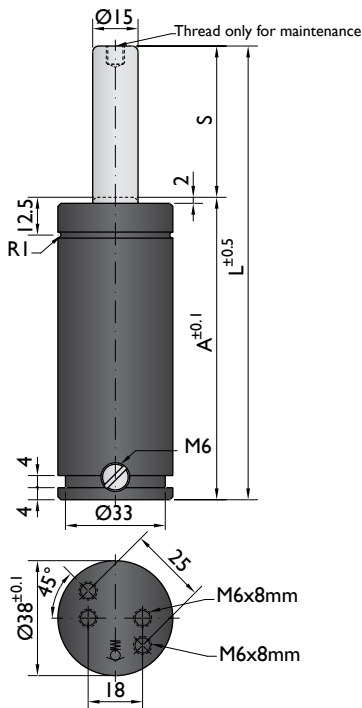

Ordering example: 4 x GGS I 00250 080

Order No.	NITROGAS	S mm	L mm	A mm	F ₀ daN	F daN		kg
					(20°C, 150 bar)			
GGS I 00250 010	CN-250-10	10	70	60	265	310	No	0.40
GGS I 00250 013	CN-250-13	12.7	75.4	62.7		310	No	0.42
GGS I 00250 025	CN-250-25	25	100	75		330	No	0.51
GGS I 00250 050	CN-250-50	50	150	100		350	No	0.63
GGS I 00250 080	CN-250-80	80	210	130		360	No	0.81
GGS I 00250 125	CN-250-125	125	300	175		360	No	1.10



Pressure medium	N ₂	Working temperature	0-80°C	Min. security stroke	10%
Max. Charging pressure	150 bar	Temperature related force increase	+0.34%/°C	Repair Kit	KIT-CN-250
Min. Charging pressure	25 bar	Max. working speed	1.6 m/s	Linkable	M6

Mounting possibilities



The gas spring must be fixed by flanges or by bottom with screws and lock washer.

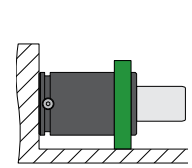
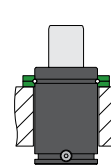
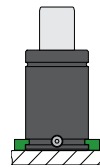
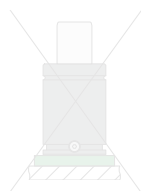
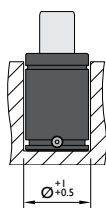
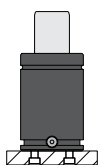

Flange must not support spring's force

Flanges

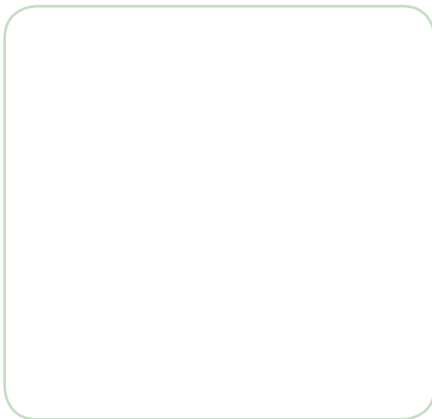
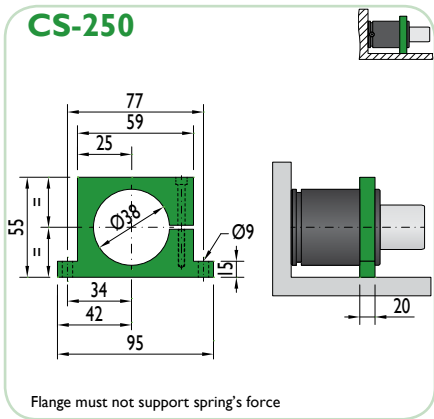
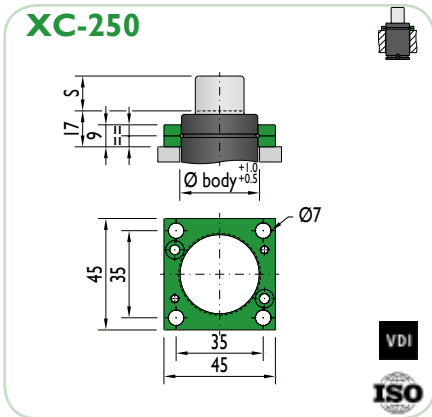
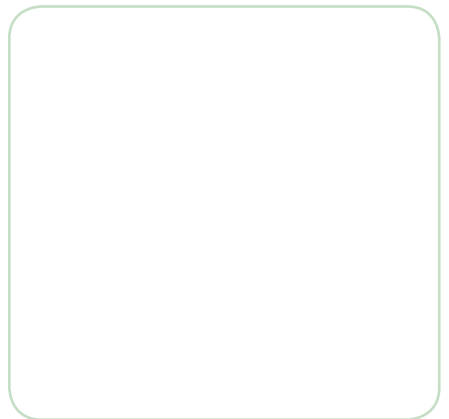
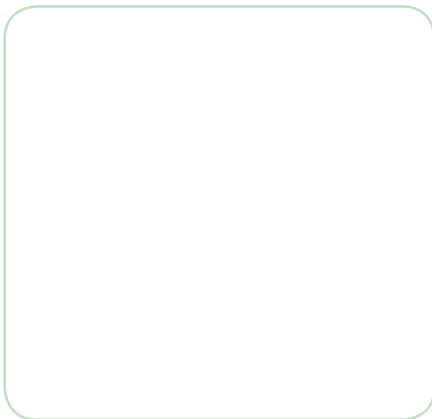
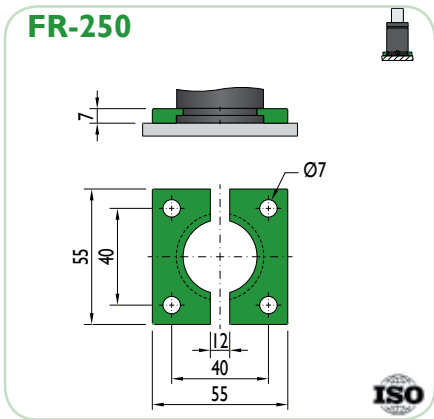



CNOMO
EM24.54.700

PSA
E24.54.815.G

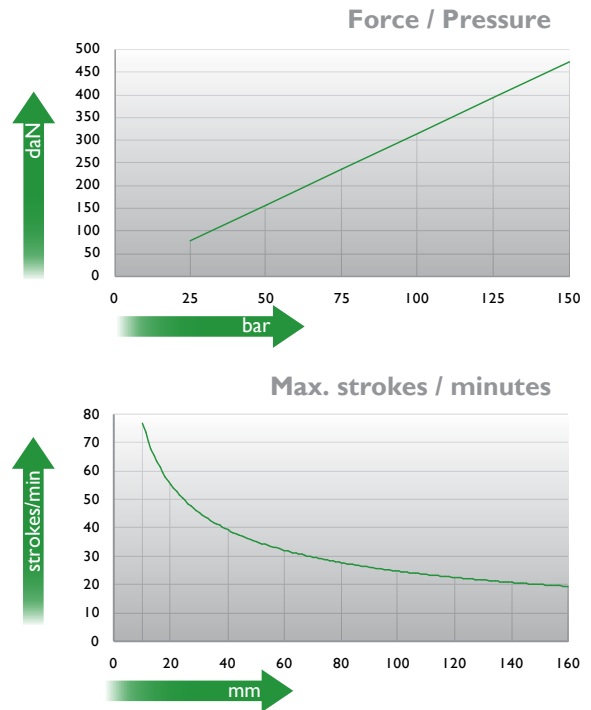
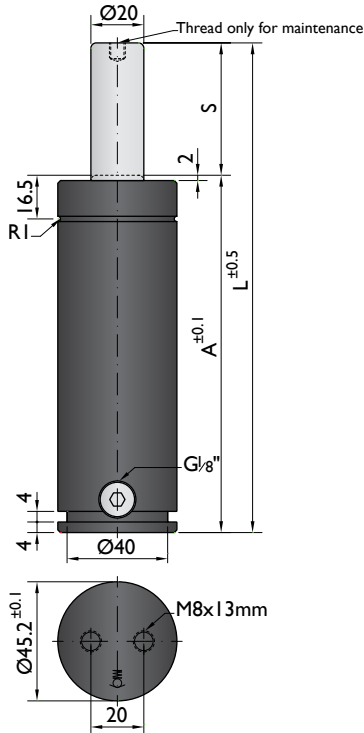

Ordering example: 4 x GGS I 00500 080

Order No.	NITROGAS	S mm	L mm	A mm	F_0 daN (20°C, 150 bar)	F daN		kg
GGS I 00500 025	CN-500-25	25	135	110	470	580	No	0.87
GGS I 00500 050	CN-500-50	50	185	135		620	No	1.06
GGS I 00500 080	CN-500-80	80	245	165		650	No	1.34
GGS I 00500 125	CN-500-125	125	335	210		680	No	1.72



Pressure medium	N ₂	Working temperature	0-80°C	Min. security stroke	10%
Max. Charging pressure	150 bar	Temperature related force increase	+0.34%/°C	Repair Kit	KIT CN-500
Min. Charging pressure	25 bar	Max. working speed	1.6 m/s	Linkable	G1/8"

Mounting possibilities



The gas spring must be fixed by flanges or by bottom with screws and lock washer.

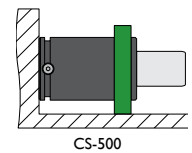
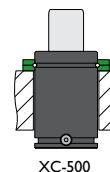
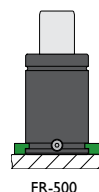
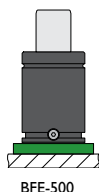
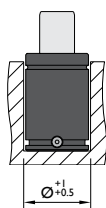
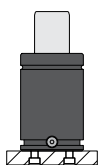

Flange must not support spring's force

Flanges

BFE-500

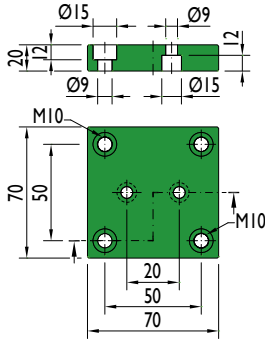

FR-500

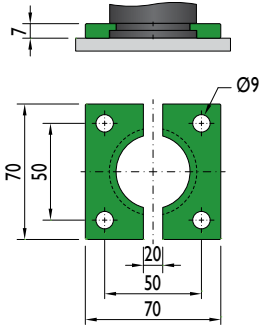

XC-500

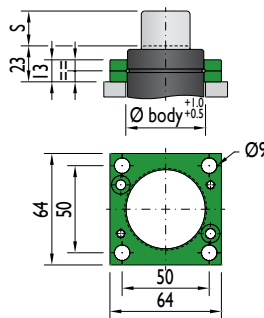

CS-500

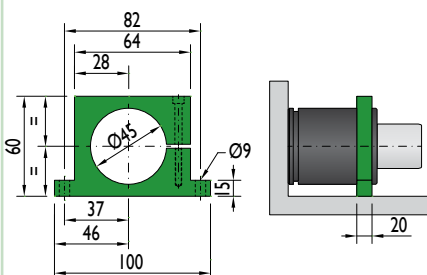

Flange must not support spring's force



CNOMO
EM24.54.700

PSA
E24.54.815.G

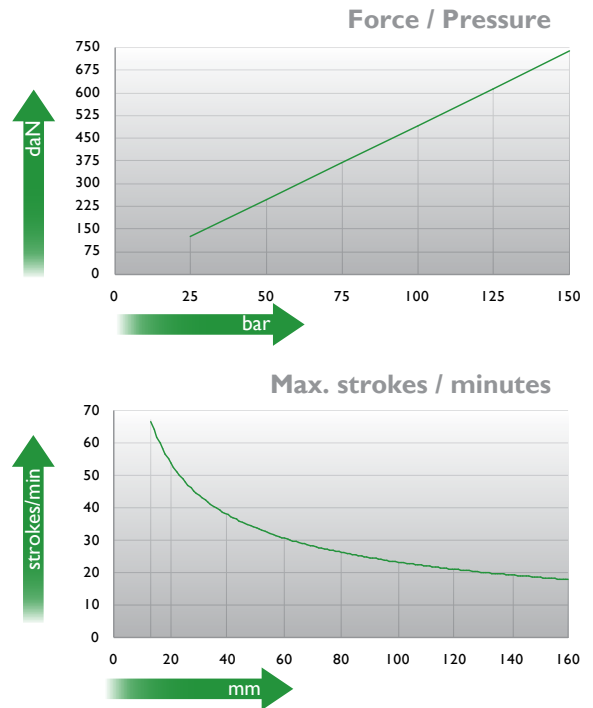
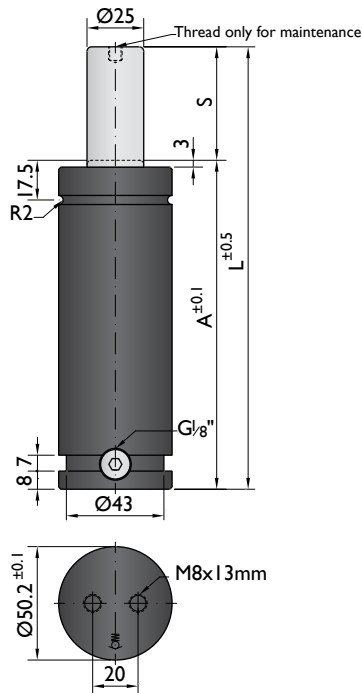

Ordering example: 4 x GGS I 00750 080

Order No.	NITROGAS	S mm	L mm	A mm	F daN (20°C, 150 bar)	F daN	kg
GGG I 00750 025	G-750-25	25	145	120		900	1.21
GGG I 00750 050	G-750-50	50	195	145		900	1.50
GGG I 00750 080	G-750-80	80	255	175	740	1000	1.63
GGG I 00750 125	G-750-125	125	345	220		1000	2.01
GGG I 00750 160	G-750-160	160	415	255		1100	3.80



Pressure medium	N ₂	Working temperature	0-80°C	Min. security stroke	10%
Max. Charging pressure	150 bar	Temperature related force increase	+0.34%/°C	Repair Kit	KIT G-750
Min. Charging pressure	25 bar	Max. working speed	1.6 m/s	Linkable	G1/8"

Mounting possibilities



The gas spring must be fixed by flanges or by bottom with screws and lock washer.

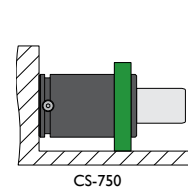
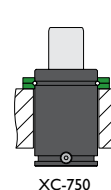
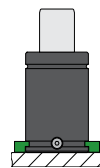
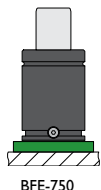
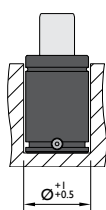
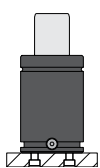

Flange must not support spring's force

Flanges

BFE-750

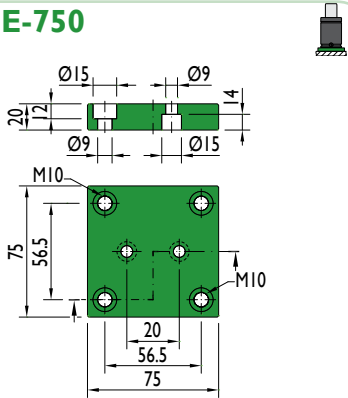

GR-750

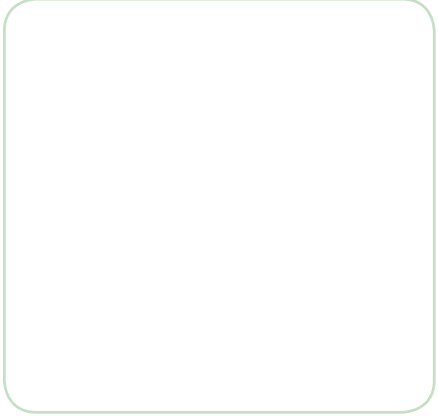
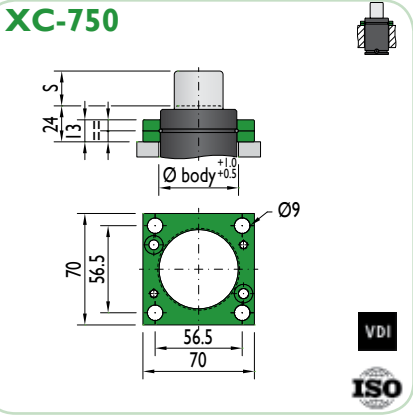
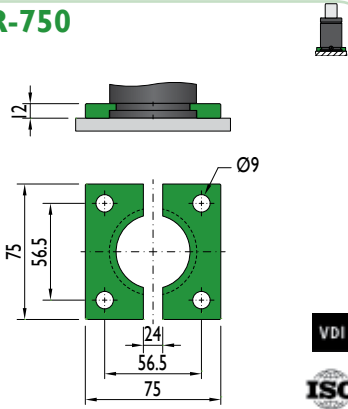

XC-750

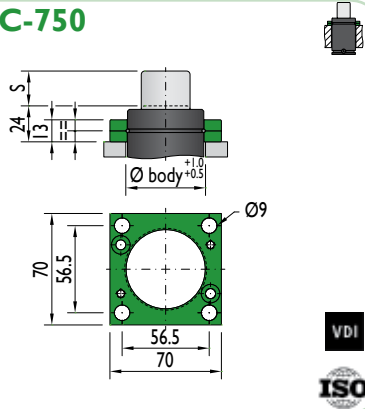

CS-750

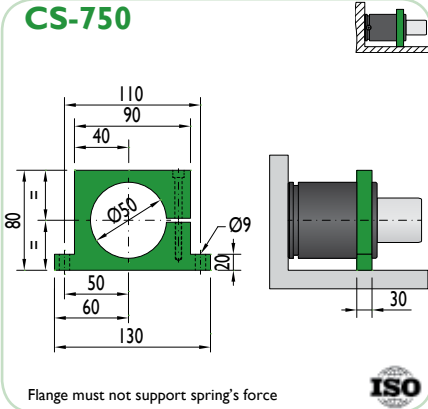



CNOMO
EM24.54.700

PSA
E24.54.815.G

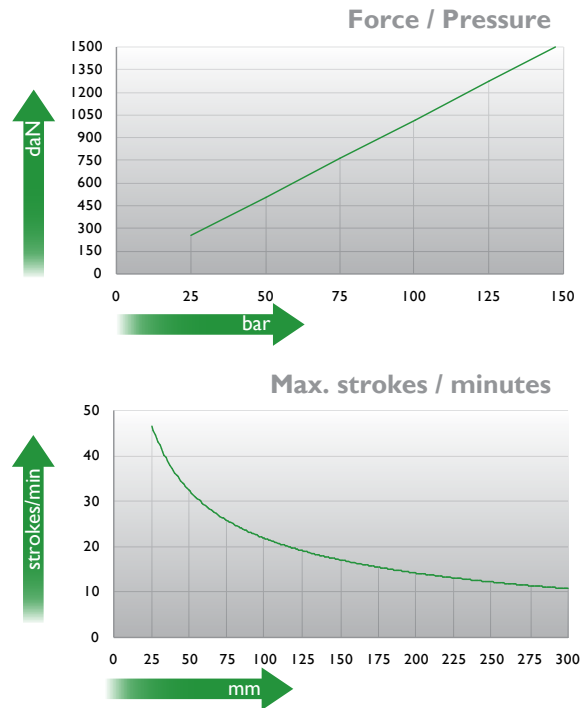
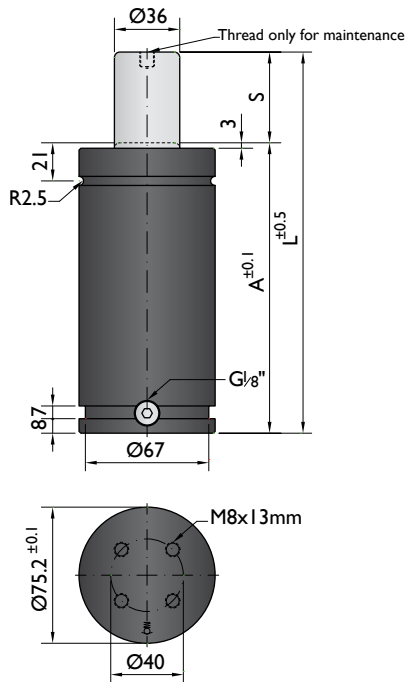

Ordering example: 4 x GGS I 01500 080

Order No.	NITROGAS	S mm	L mm	A mm	F ₀ daN	F daN		kg
					(20°C, 150 bar)			
GGS I 01500 025	G-1500-25	25	160	135	1500	1800	No	3.48
GGS I 01500 050	G-1500-50	50	210	160		2000	No	4.05
GGS I 01500 080	G-1500-80	80	270	190		2000	No	4.37
GGS I 01500 125	G-1500-125	125	360	235		2100	Yes	4.87
GGS I 01500 160	G-1500-160	160	430	270		2100	Yes	5.29
GGS I 01500 200	G-1500-200	200	510	310		2100	Yes	6.75



Pressure medium	N ₂	Working temperature	0-80°C	Min. security stroke	10%
Max. Charging pressure	150 bar	Temperature related force increase	+0.34%/°C	Repair Kit	KIT G-1500
Min. Charging pressure	25 bar	Max. working speed	1.6 m/s	Linkable	G1/8"

Mounting possibilities



The gas spring must be fixed by flanges or by bottom with screws and lock washer.

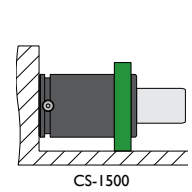
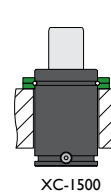
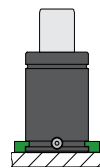
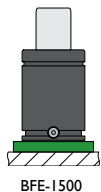
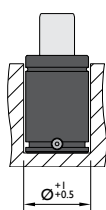
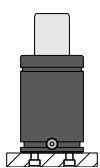

Flange must not support spring's force

Flanges

BFE-1500

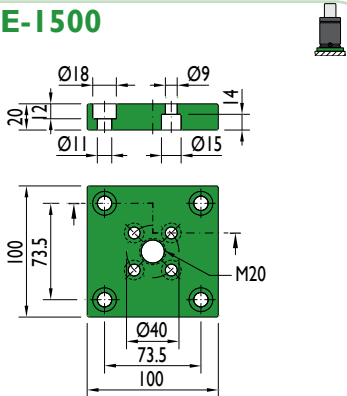

GR-1500

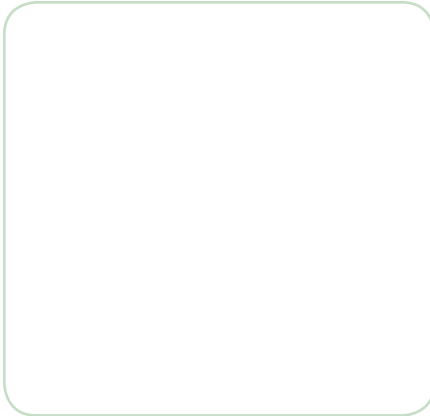
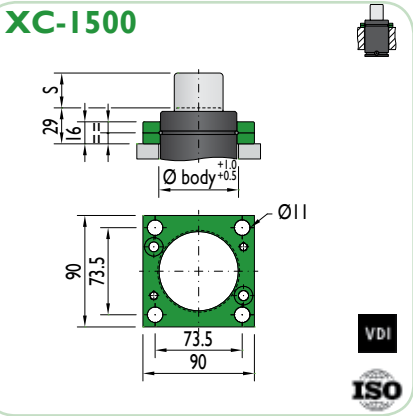
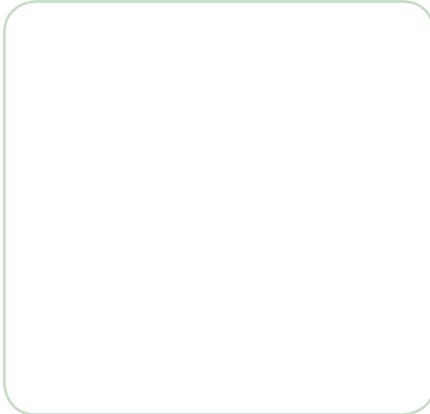
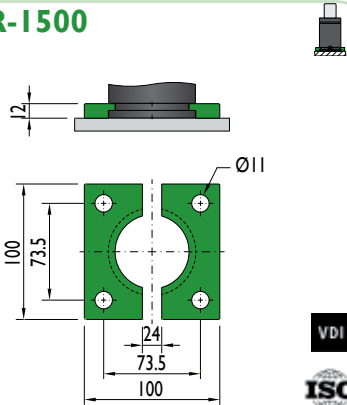

CS-1500

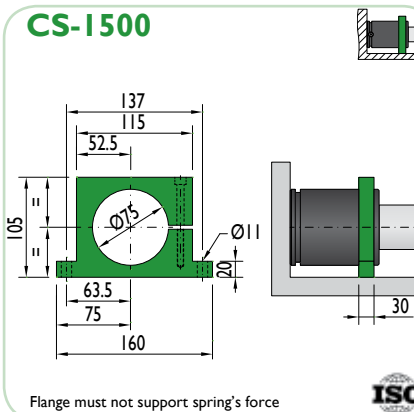

Flange must not support spring's force





CNOMO
EM24.54.700

PSA
E24.54.815.G

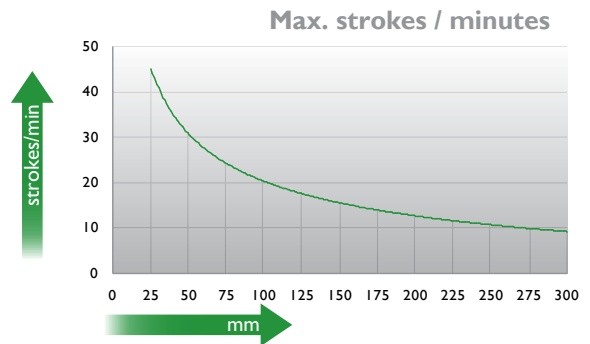
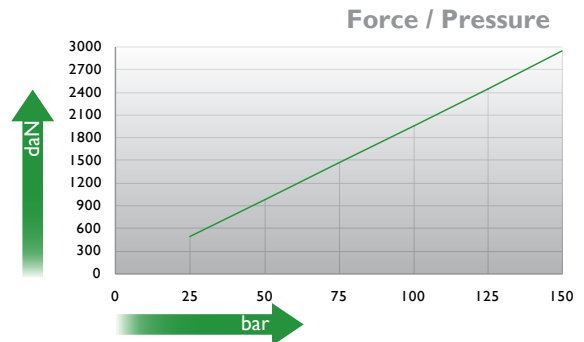
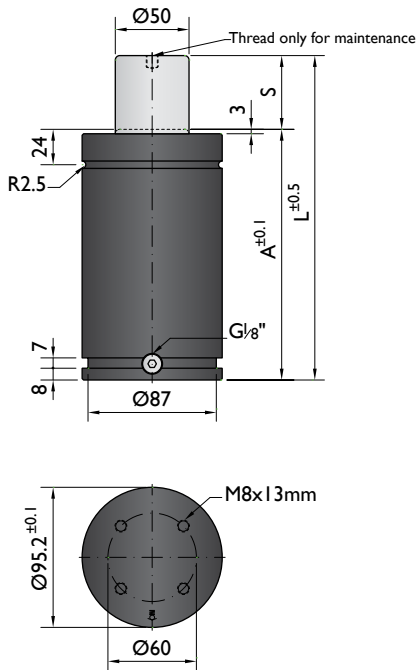

Ordering example: 4 x GGS I 03000 080

Order No.	NITROGAS	S mm	L mm	A mm	F ₀ daN	F daN		kg
					(20°C, 150 bar)			
GGS I 03000 025	G-3000-25	25	170	145	3000	3500	No	5.86
GGS I 03000 050	G-3000-50	50	220	170		3800	No	6.66
GGS I 03000 080	G-3000-80	80	280	200		4000	No	8.28
GGS I 03000 125	G-3000-125	125	370	245		4200	Yes	8.97
GGS I 03000 200	G-3000-200	200	520	320		4300	Yes	10.92



Pressure medium	N ₂	Working temperature	0-80°C	Min. security stroke	10%
Max. Charging pressure	150 bar	Temperature related force increase	+0.34%/°C	Repair Kit	KIT G-3000
Min. Charging pressure	25 bar	Max. working speed	1.6 m/s	Linkable	G1/8"

Mounting possibilities



The gas spring must be fixed by flanges or by bottom with screws and lock washer.

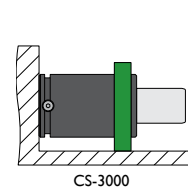
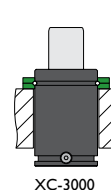
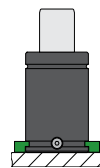
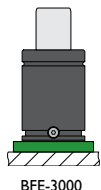
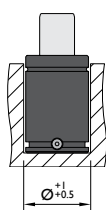
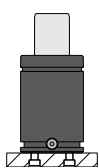

Flange must not support spring's force

Flanges

BFE-3000

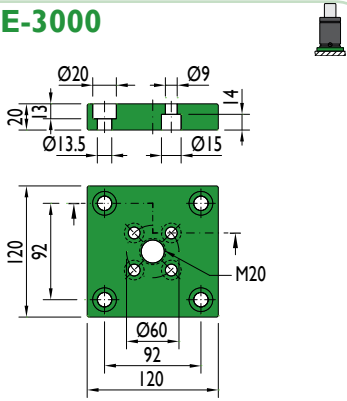

GR-3000

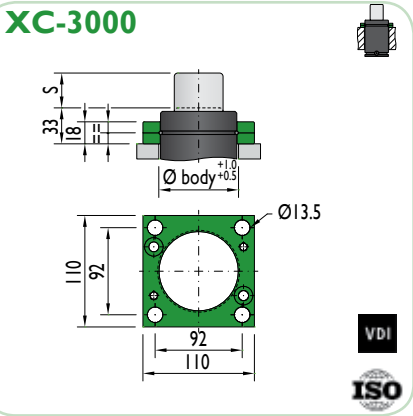
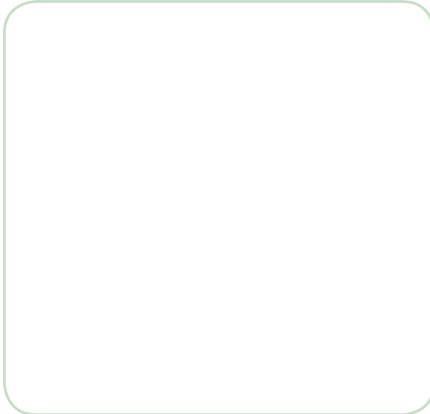
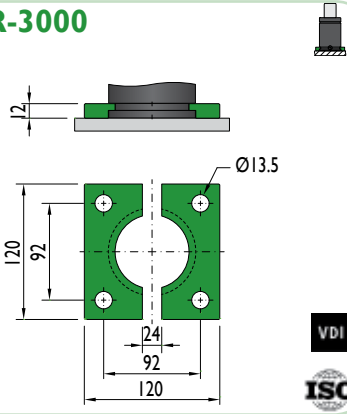

CS-3000

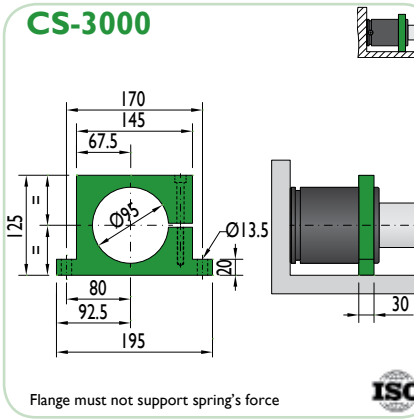

Flange must not support spring's force



CNOMO
EM24.54.700

PSA
E24.54.815.G

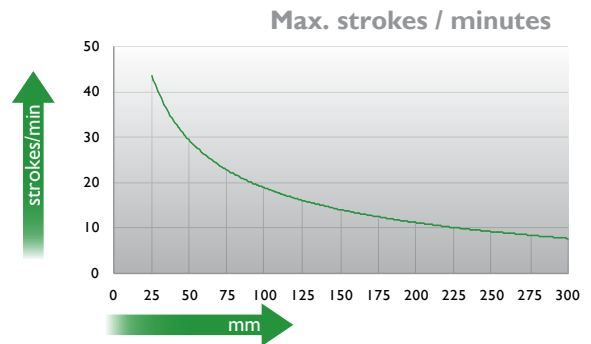
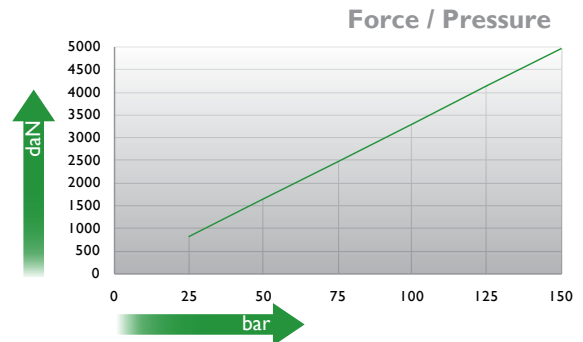
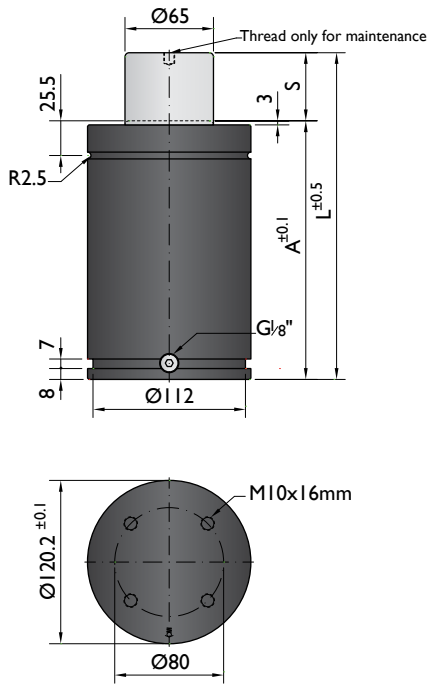

Ordering example: 4 x GGS I 05000 080

Order No.	NITROGAS	S mm	L mm	A mm	F ₀ daN	F daN		kg
					(20°C, 150 bar)			
GGS I 05000 025	G-5000-25	25	190	165	5000	5900	No	10.76
GGS I 05000 050	G-5000-50	50	240	190		6400	No	11.80
GGS I 05000 080	G-5000-80	80	300	220		6700	No	13.21
GGS I 05000 125	G-5000-125	125	390	265		7300	Yes	16.25
GGS I 05000 200	G-5000-200	200	540	340		7500	Yes	21.16



Pressure medium	N ₂	Working temperature	0-80°C	Min. security stroke	10%
Max. Charging pressure	150 bar	Temperature related force increase	+0.34%/°C	Repair Kit	KIT G-5000
Min. Charging pressure	25 bar	Max. working speed	1.6 m/s	Linkable	G1/8"

Mounting possibilities



The gas spring must be fixed by flanges or by bottom with screws and lock washer.

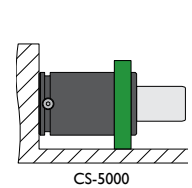
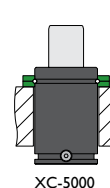
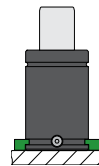
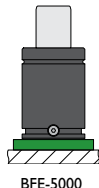
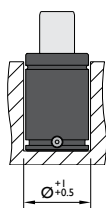
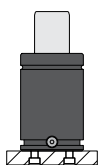

Flange must not support spring's force

Flanges

BFE-5000

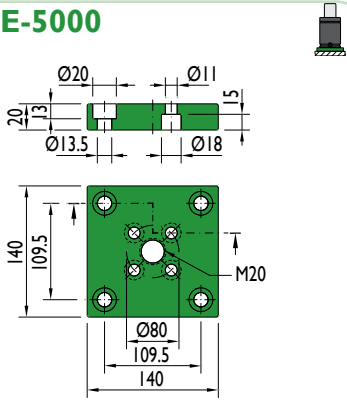

GR-5000

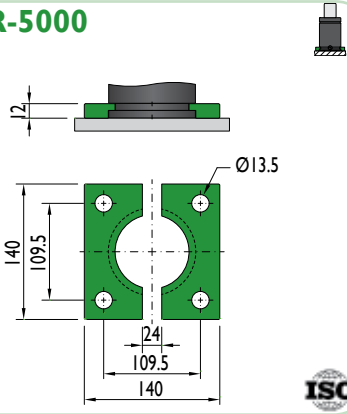

XC-5000

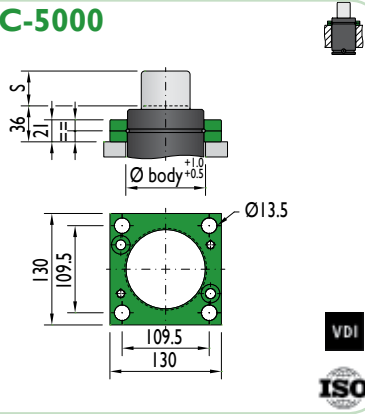

CS-5000

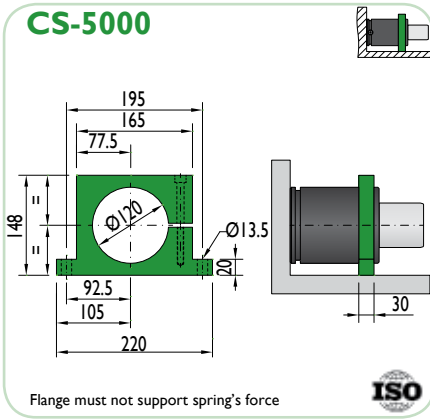

Flange must not support spring's force





CNOMO
EM24.54.700

PSA
E24.54.815.G

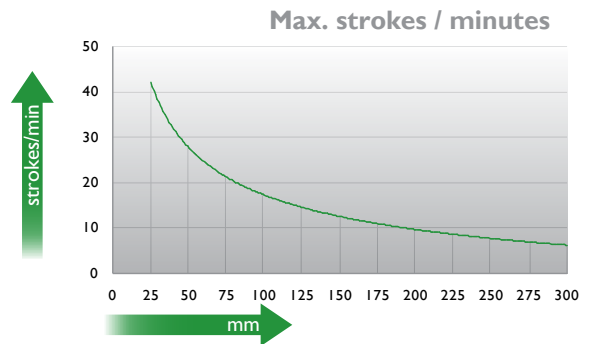
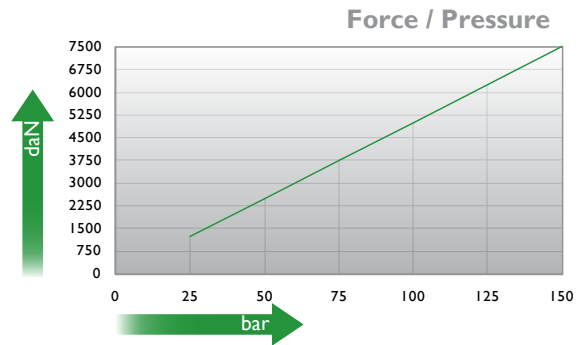
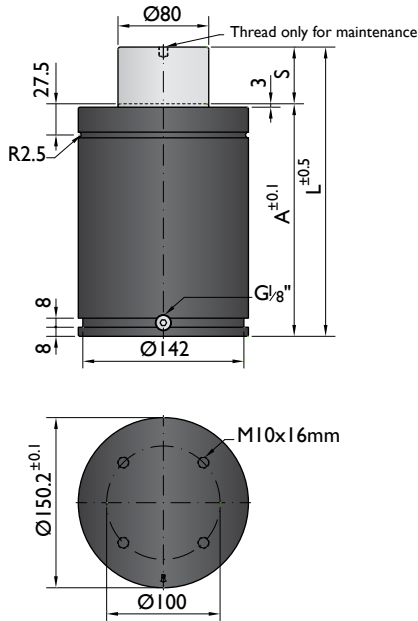

Ordering example: 4 x GGS I 07500 080

Order No.	NITROGAS	S mm	L mm	A mm	F_0 daN (20°C, 150 bar)	F daN		kg
GGS I 07500 025	CN-7500-25	25	205	180	7500	9000	No	18.06
GGS I 07500 050	CN-7500-50	50	255	205		9700	No	20.30
GGS I 07500 080	CN-7500-80	80	315	235		10100	No	22.21
GGS I 07500 125	CN-7500-125	125	405	280		10700	Yes	24.96
GGS I 07500 200	CN-7500-200	200	555	355		11100	Yes	29.81



Pressure medium	N ₂	Working temperature	0-80°C	Min. security stroke	10%
Max. Charging pressure	150 bar	Temperature related force increase	+0.34%/°C	Repair Kit	KIT CN-7500
Min. Charging pressure	25 bar	Max. working speed	1.6 m/s	Linkable	G1/8"

Mounting possibilities



The gas spring must be fixed by flanges or by bottom with screws and lock washer.

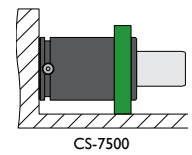
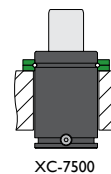
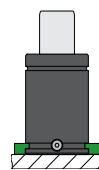
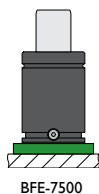
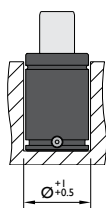
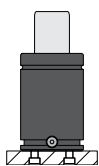

Flange must not support spring's force

Flanges

BFE-7500

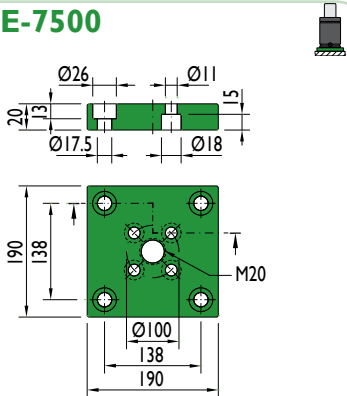

GR-7500

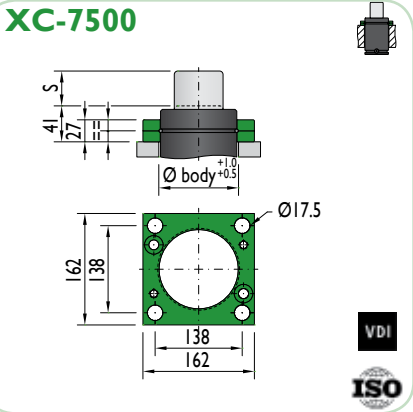
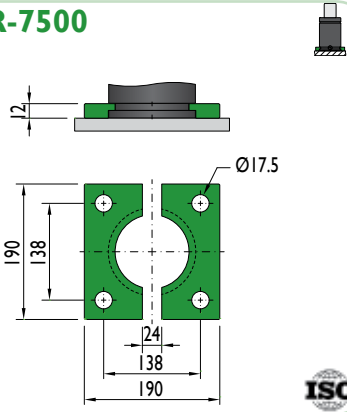

CS-7500

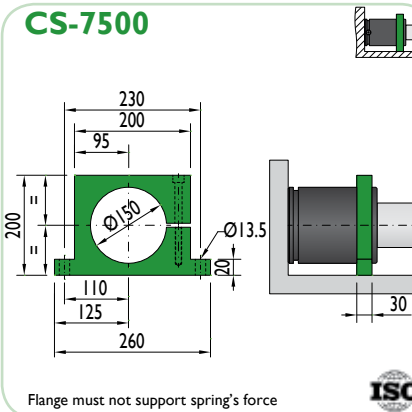

Flange must not support spring's force

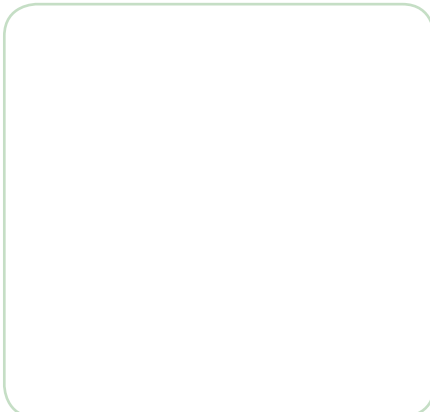



CNOMO
EM24.54.700

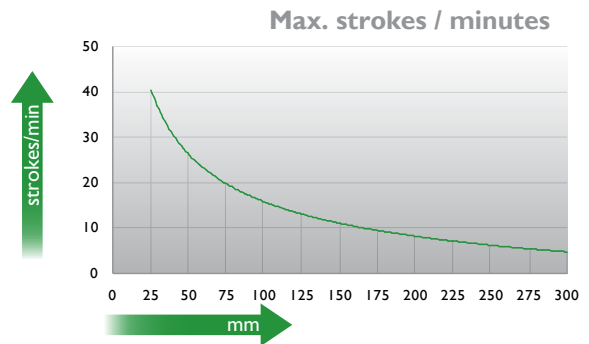
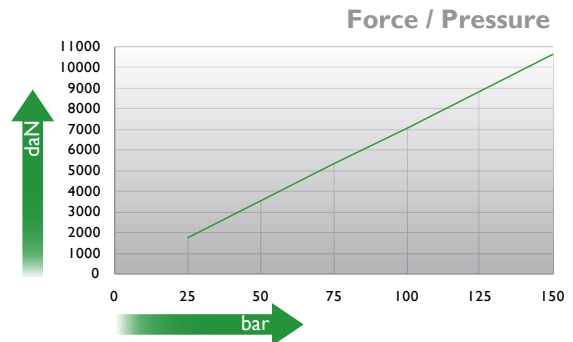
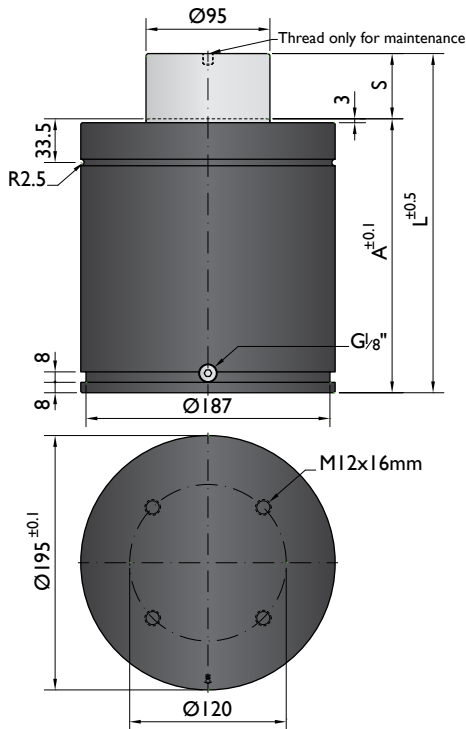

Ordering example: 4 x GGS I 10000 080

Order No.	NITROGAS	S mm	L mm	A mm	F ₀ daN	F daN		kg
					(20°C, 150 bar)			
GGS I 10000 050	CN-10000-50	50	260	210	10600	13800	No	36.20
GGS I 10000 080	CN-10000-80	80	320	240		14200	No	40.70
GGS I 10000 100	CN-10000-100	100	360	260		14400	No	43.80
GGS I 10000 125	CN-10000-125	125	410	285		14800	Yes	47.60



Pressure medium	N ₂	Working temperature	0-80°C	Min. security stroke	10%
Max. Charging pressure	150 bar	Temperature related force increase	+0.34%/°C	Repair Kit	KIT CN-10000
Min. Charging pressure	25 bar	Max. working speed	1.6 m/s	Linkable	G1/8"

Mounting possibilities



The gas spring must be fixed by flanges or by bottom with screws and lock washer.

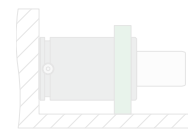
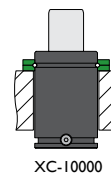
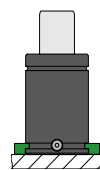
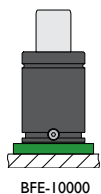
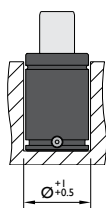
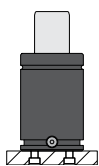

Flanges

BFE-10000

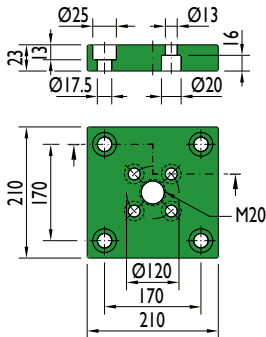

GR-10000

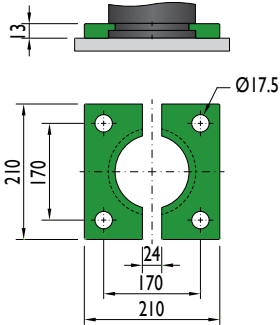

XC-10000

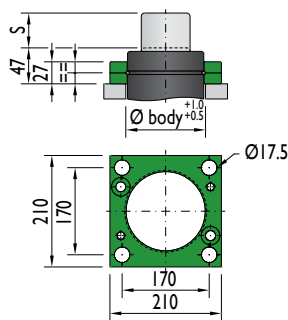

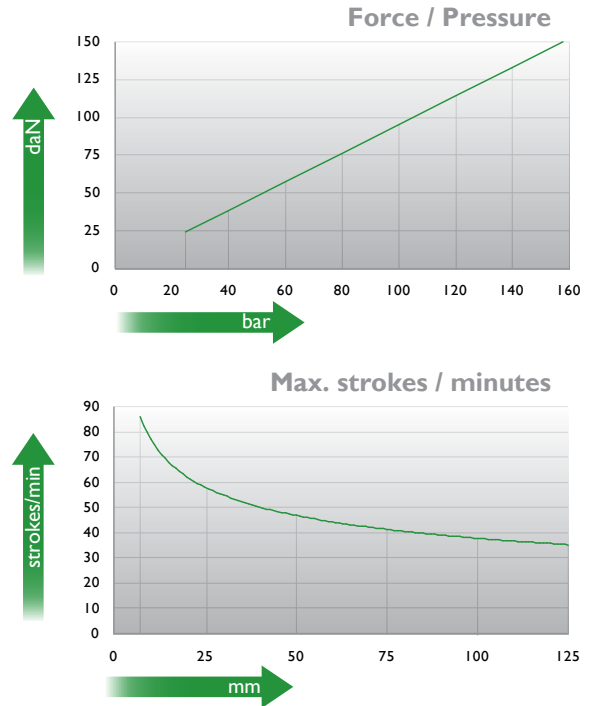
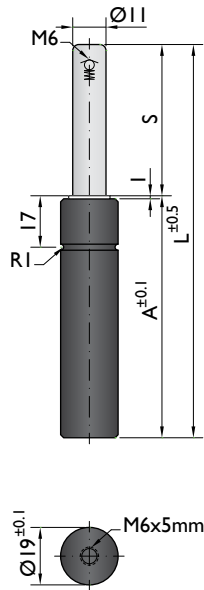

Ordering example: 4 x GGS C 00150 080

Order No.	NITROGAS	S mm	L mm	A mm	F ₀ daN	F daN		kg
					(20°C, 160 bar)			
GGC C 00150 010	KP-150-10 ^(*)	10	50	40		250	No	0.07
GGC C 00150 025	KP-150-25	25	80	55		280	No	0.09
GGC C 00150 050	KP-150-50	50	130	80	150	280	No	0.12
GGC C 00150 080	KP-150-80	80	195	115		280	No	0.17
GGC C 00150 125	KP-150-125	125	285	160		280	No	0.23

(*) Gas spring without threaded hole in the bottom



Use KP model only if it is not possible to assemble an ISO gas spring.



Pressure medium	N ₂	Working temperature	0-80°C	Min. security stroke	10%
Max. Charging pressure	160 bar	Temperature related force increase	+0.34%/°C	Repair Kit	Non-repairable
Min. Charging pressure	25 bar	Max. working speed	1.6 m/s	Linkable	No

Mounting possibilities



The gas spring must be fixed by flanges or by bottom with screws and lock washer.

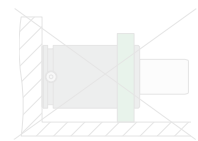
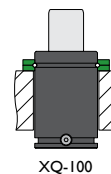
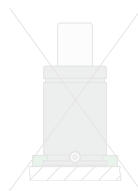
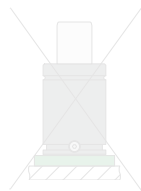
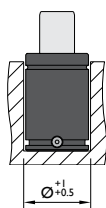
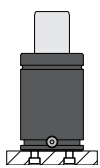

Flanges

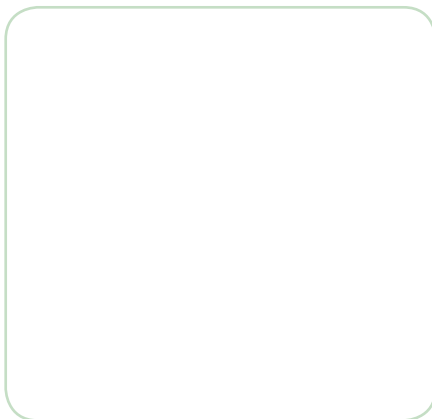
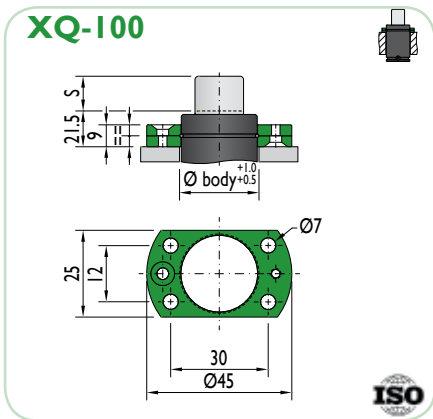



*The new cylinder will be supplied when the stock runs out.



NEW MODEL*

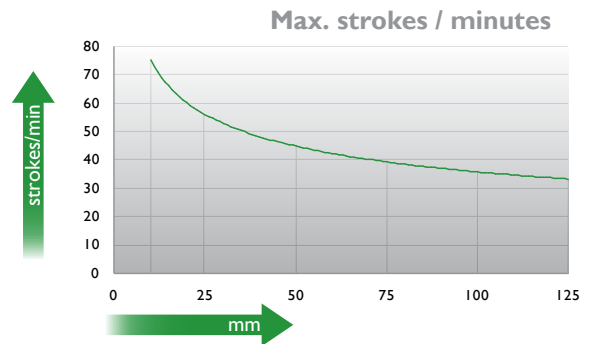
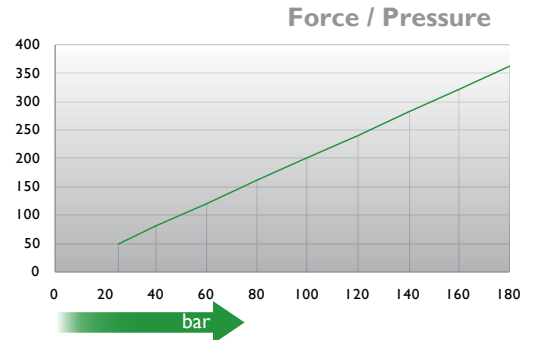
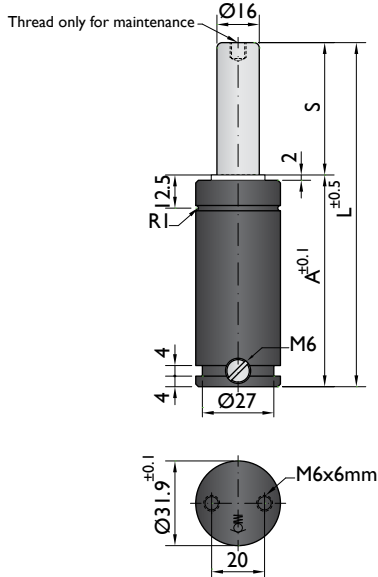

Ordering example: 4 x GGS C 00350 080

Order No.	NITROGAS	S mm	L mm	A mm	F ₀ daN	F daN	kg
GGG C 00350 013	KP-350-13	13	56	43	360	530	0.17
GGG C 00350 025	KP-350-25	25	80	55		530	0.21
GGG C 00350 038	KP-350-38	38	106	68		530	0.25
GGG C 00350 050	KP-350-50	50	130	80		540	0.29
GGG C 00350 080	KP-350-80	80	190	110		540	0.38
GGG C 00350 100	KP-350-100	100	230	130		540	0.45



Use KP model only if it is not possible to assemble an ISO gas spring.



Pressure medium	N ₂	Working temperature	0-80°C	Min. security stroke	10%
Max. Charging pressure	180 bar	Temperature related force increase	+0.34%/°C	Repair Kit	KIT KP-350
Min. Charging pressure	25 bar	Max. working speed	1.6 m/s	Linkable	M6

Mounting possibilities



The gas spring must be fixed by flanges or by bottom with screws and lock washer.

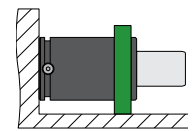
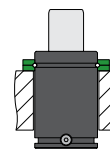
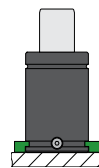
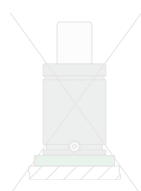
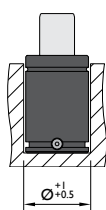
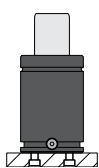

Flange must not support spring's force

Flanges



GR-300

ISO

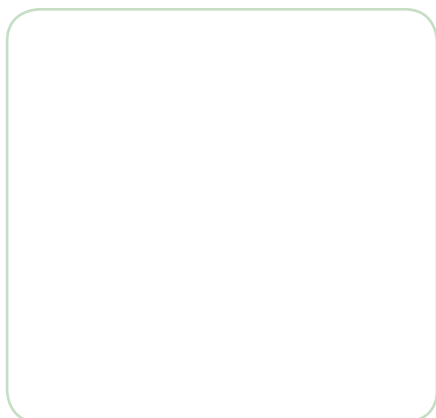
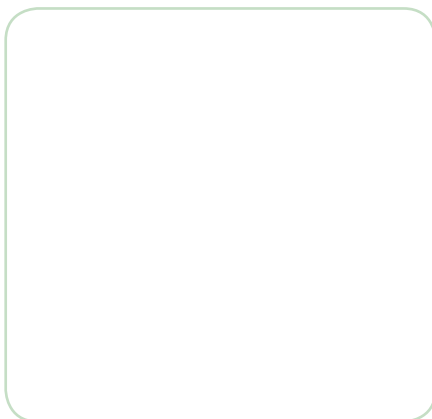

XC-150

VDI

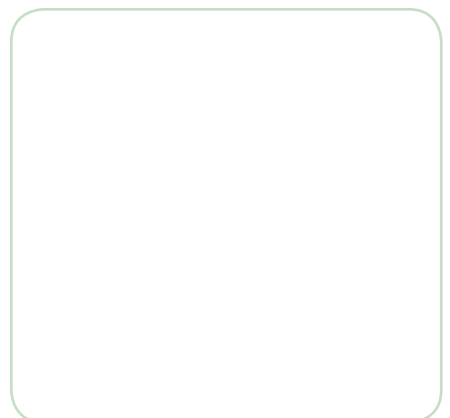

CS-150

Flange must not support spring's force

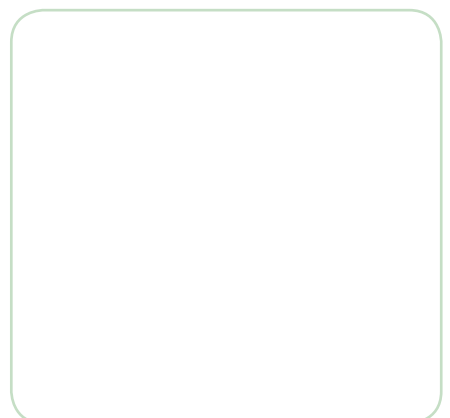
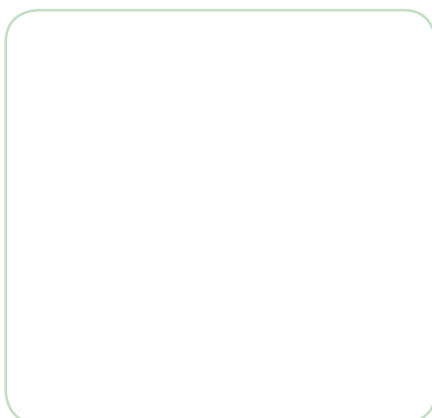



*The new cylinder will be supplied when the stock runs out.



Thread only for maintenance

NEW MODEL*



PSA
E24.54.815.G

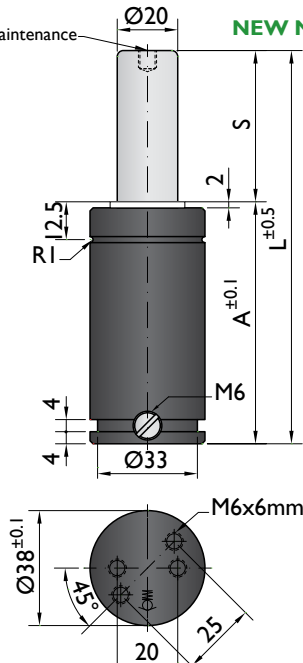

Force / Pressure

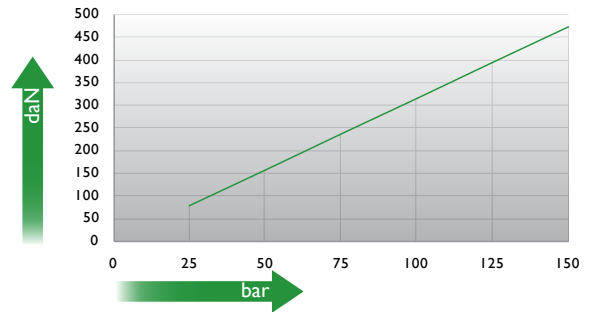

Max. strokes / minutes

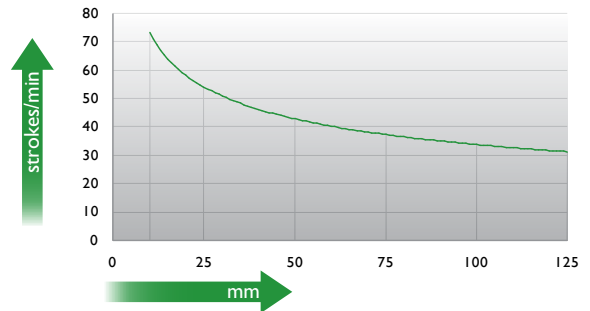

Ordering example: 4 x GGS C 00500 080

Order No.	NITROGAS	S mm	L mm	A mm	F ₀ daN (20°C, 150 bar)	F daN	kg
GGC C 00500 013	KP-500-13	13	56	43	470	680	0.31
GGC C 00500 025	KP-500-25	25	80	55		690	0.42
GGC C 00500 050	KP-500-50	50	130	80		700	0.66
GGC C 00500 080	KP-500-80	80	190	110		710	0.98
GGC C 00500 100	KP-500-100	100	230	130		710	1.15



Use KP model only if it is not possible to assemble an ISO gas spring.



Pressure medium	N ₂	Working temperature	0-80°C	Min. security stroke	10%
Max. Charging pressure	150 bar	Temperature related force increase	+0.34%/°C	Repair Kit	KIT KP-500
Min. Charging pressure	25 bar	Max. working speed	1.6 m/s	Linkable	M6

Mounting possibilities



The gas spring must be fixed by flanges or by bottom with screws and lock washer.

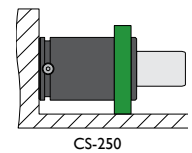
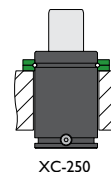
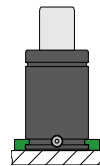
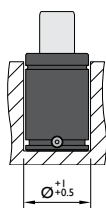
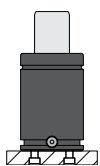

Flange must not support spring's force

Flanges

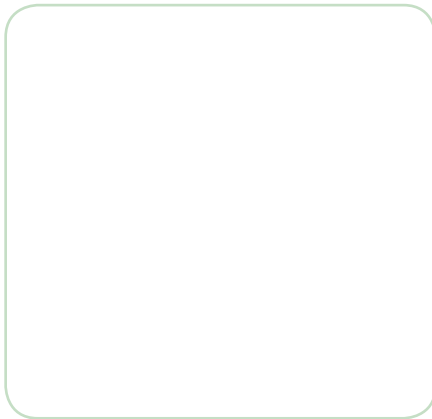

FR-250

ISO

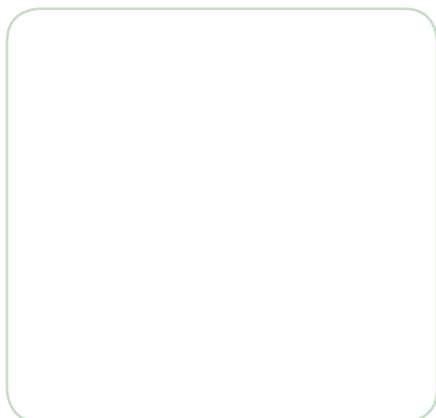
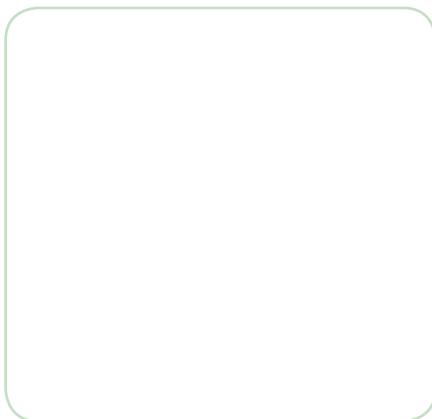

XC-250

VDI
ISO



CS-250

Flange must not support spring's force

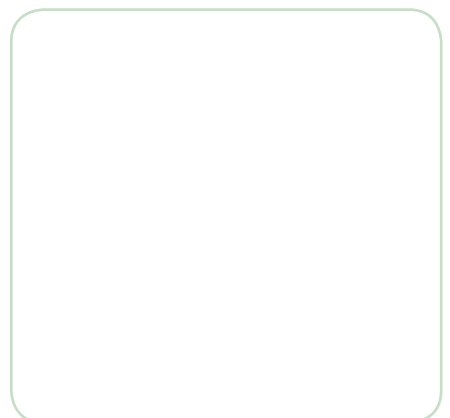
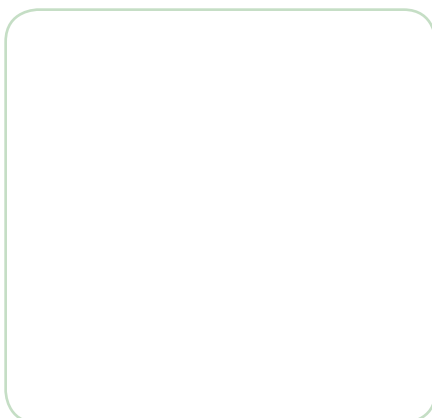



*The new cylinder will be supplied when the stock runs out.



NEW MODEL*

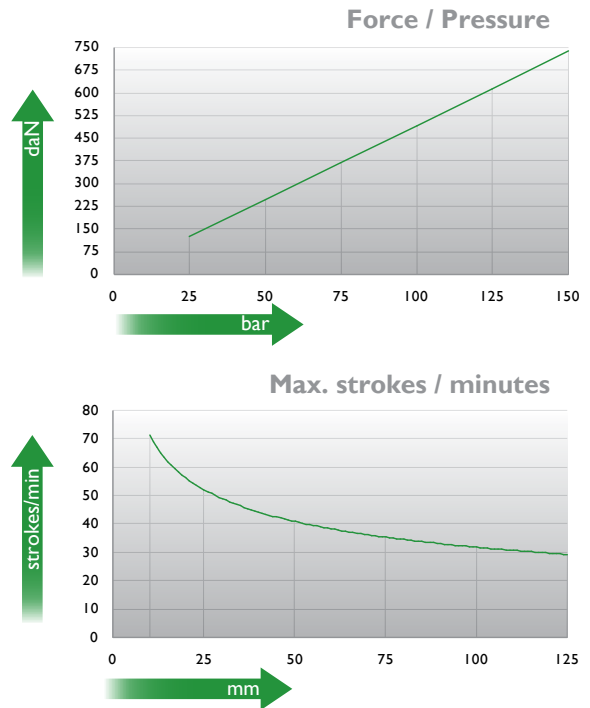
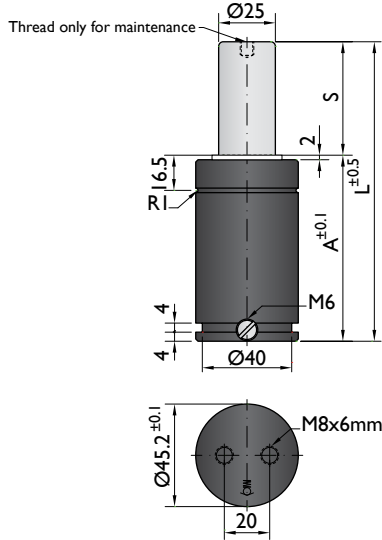

Ordering example: 4 x GGS C 00750 080

Order No.	NITROGAS	S mm	L mm	A mm	F ₀ daN (20°C, 150 bar)	F daN	kg
GGC C 00750 013	KP-750-13	13	58	45	740	1000	0.41
GGC C 00750 025	KP-750-25	25	82	57		1100	0.45
GGC C 00750 038	KP-750-38	38	108	70		1100	0.58
GGC C 00750 050	KP-750-50	50	132	82		1100	0.67
GGC C 00750 080	KP-750-80	80	192	112		1100	0.87
GGC C 00750 100	KP-750-100	100	232	132		1100	1.01



Use KP model only if it is not possible to assemble an ISO gas spring.



Pressure medium	N ₂	Working temperature	0-80°C	Min. security stroke	10%
Max. Charging pressure	150 bar	Temperature related force increase	+0.34%/°C	Repair Kit	KIT KP-750
Min. Charging pressure	25 bar	Max. working speed	1.6 m/s	Linkable	M6

Mounting possibilities



The gas spring must be fixed by flanges or by bottom with screws and lock washer.

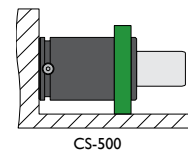
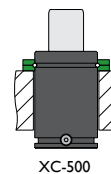
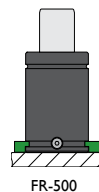
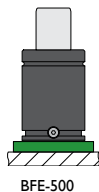
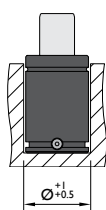
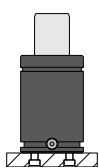

Flange must not support spring's force

Flanges

BFE-500

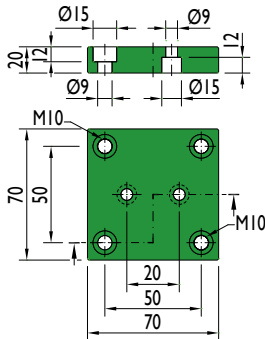

FR-500

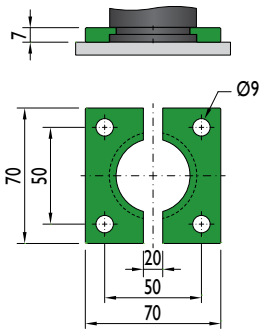

XC-500

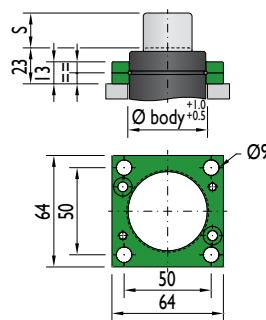

CS-500

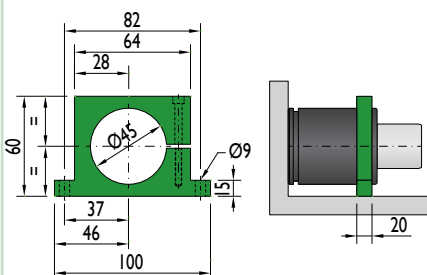

Flange must not support spring's force



*The new cylinder will be supplied when the stock runs out.



NEW MODEL*

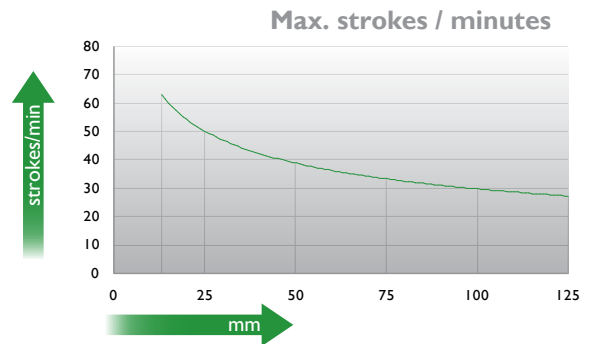
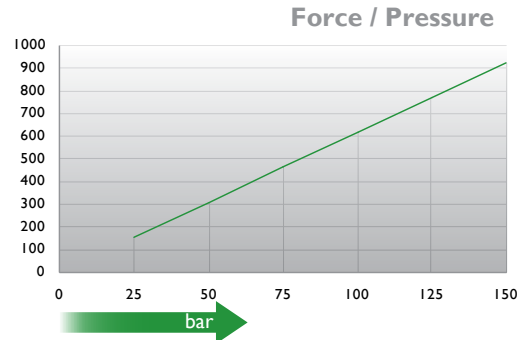
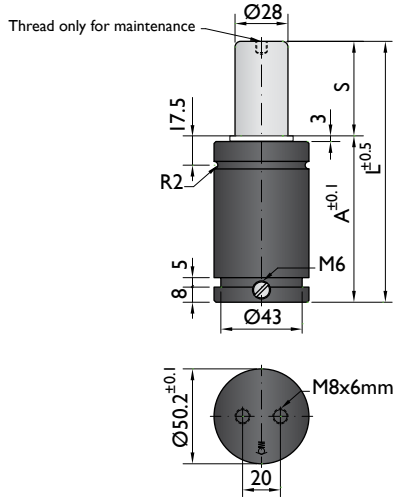

Ordering example: 4 x GGS C 01000 080

Order No.	NITROGAS	S mm	L mm	A mm	F ₀ daN (20°C, 150 bar)	F daN	kg
GGS C 01000 016	KP-1000-16	16	70	54		1400	0.59
GGS C 01000 025	KP-1000-25	25	88	63		1400	0.67
GGS C 01000 050	KP-1000-50	50	138	88	920	1400	0.88
GGS C 01000 080	KP-1000-80	80	198	118		1400	1.13
GGS C 01000 100	KP-1000-100	100	238	138		1400	1.30



Use KP model only if it is not possible to assemble an ISO gas spring.



Pressure medium	N ₂	Working temperature	0-80°C	Min. security stroke	10%
Max. Charging pressure	150 bar	Temperature related force increase	+0.34%/°C	Repair Kit	KIT KP-1000
Min. Charging pressure	25 bar	Max. working speed	1.6 m/s	Linkable	M6

Mounting possibilities



The gas spring must be fixed by flanges or by bottom with screws and lock washer.

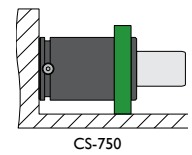
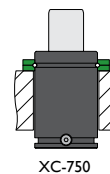
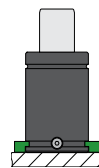
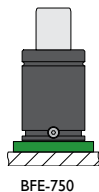
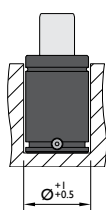
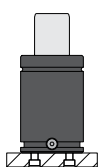

Flange must not support spring's force

Flanges

BFE-750

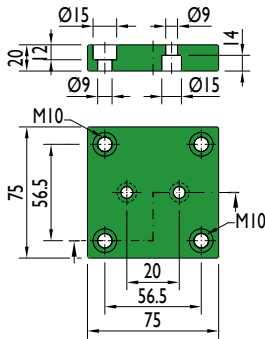

GR-750

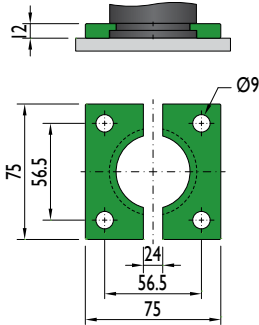

XC-750

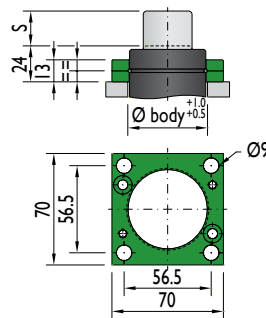

CS-750

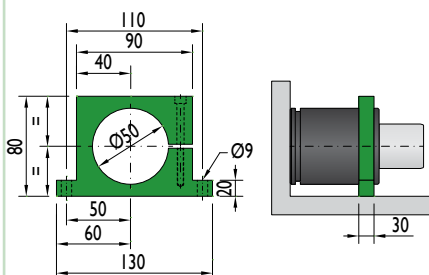

Flange must not support spring's force



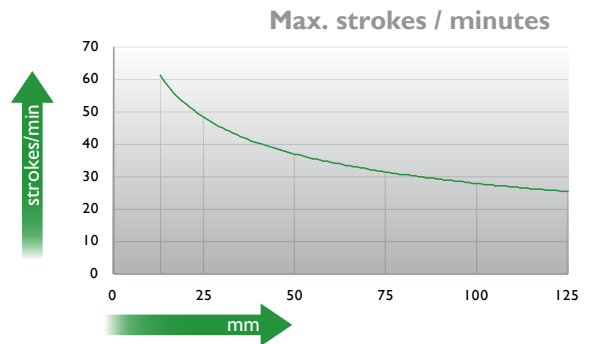
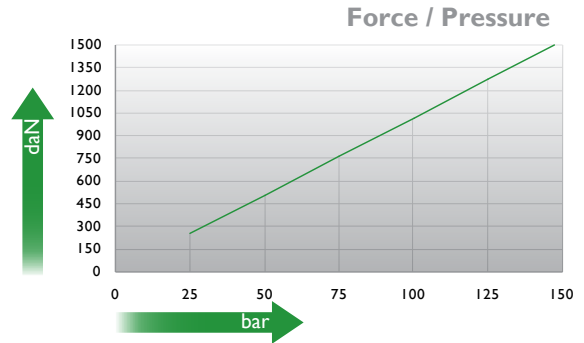
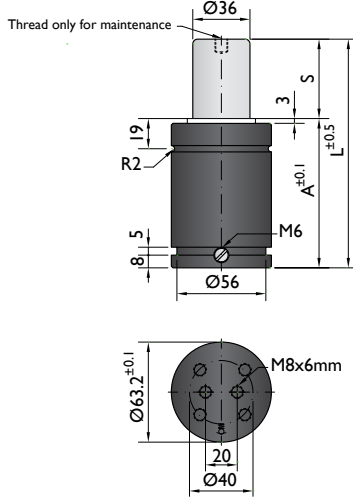

Ordering example: 4 x GGS C 01500 080

Order No.	NITROGAS	S mm	L mm	A mm	F ₀ daN	F daN		kg
					(20°C, 150 bar)			
GGS C 01500 016	KP-1500-16	16	76	60		2200	No	1.01
GGS C 01500 025	KP-1500-25	25	94	69		2200	No	1.16
GGS C 01500 050	KP-1500-50	50	144	94	1500	2400	Yes	1.57
GGS C 01500 080	KP-1500-80	80	204	124		2400	Yes	2.06
GGS C 01500 100	KP-1500-100	100	244	144		2400	Yes	2.37



Use KP model only if it is not possible to assemble an ISO gas spring.



Pressure medium	N ₂	Working temperature	0-80°C	Min. security stroke	10%
Max. Charging pressure	150 bar	Temperature related force increase	+0.34%/°C	Repair Kit	KIT KP-1500
Min. Charging pressure	25 bar	Max. working speed	1.6 m/s	Linkable	M6

Mounting possibilities



The gas spring must be fixed by flanges or by bottom with screws and lock washer.

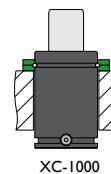
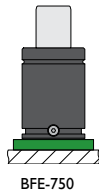
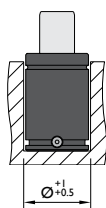
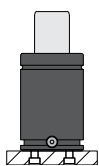

Flanges

BFE-750

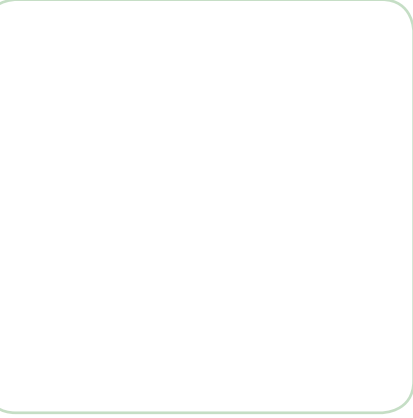
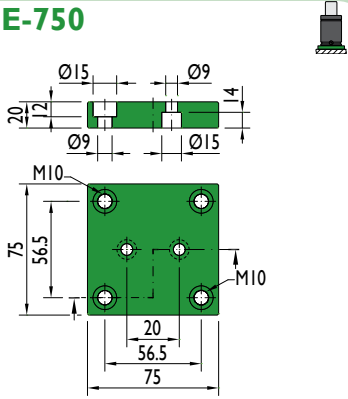

XCV-1500

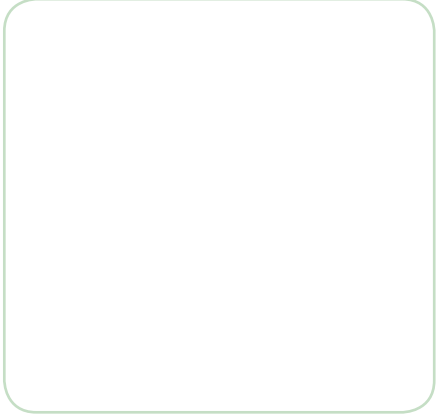
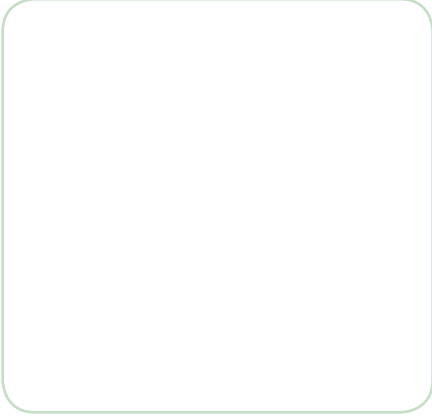
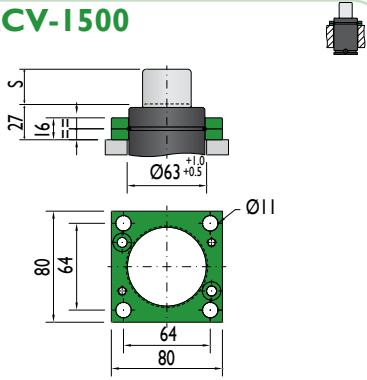



PSA
E24.54.815.G

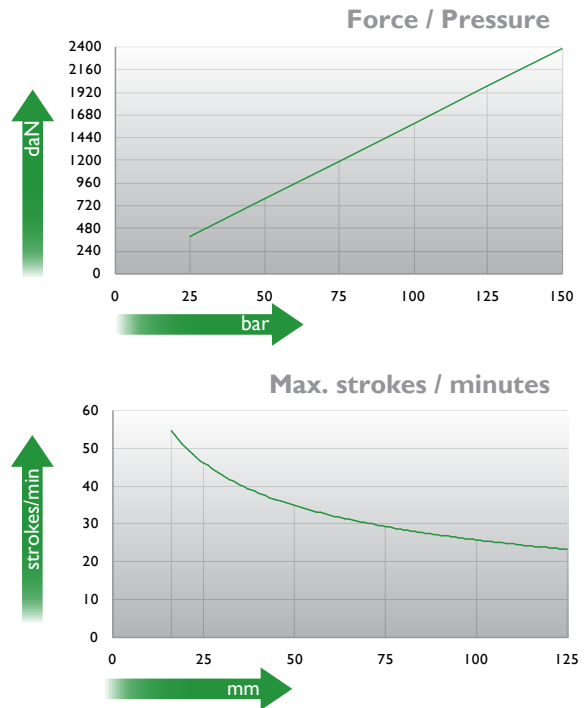
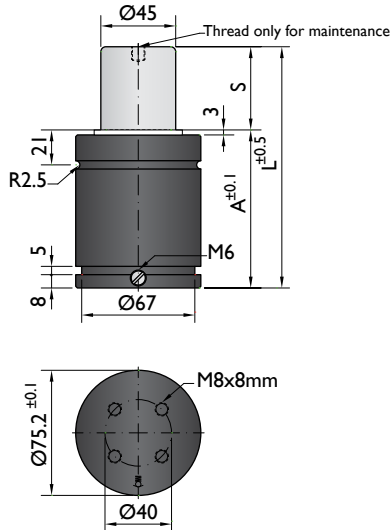

Ordering example: 4 x GGS C 02400 080

Order No.	NITROGAS	S mm	L mm	A mm	F ₀ daN	F daN		kg
					(20°C, 150 bar)			
GGG C 02400 016	KP-2400-16	16	77	61		3700	No	1.54
GGG C 02400 025	KP-2400-25	25	95	70		3900	No	1.59
GGG C 02400 050	KP-2400-50	50	145	95	2400	4300	Yes	2.25
GGG C 02400 080	KP-2400-80	80	205	125		4100	Yes	2.75
GGG C 02400 100	KP-2400-100	100	245	145		4100	Yes	3.06



Use KP model only if it is not possible to assemble an ISO gas spring.



Pressure medium	N ₂	Working temperature	0-80°C	Min. security stroke	10%
Max. Charging pressure	150 bar	Temperature related force increase	+0.34%/°C	Repair Kit	KIT KP-2400
Min. Charging pressure	25 bar	Max. working speed	1.6 m/s	Linkable	M6

Mounting possibilities



The gas spring must be fixed by flanges or by bottom with screws and lock washer.

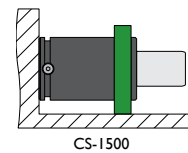
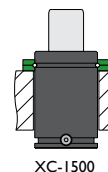
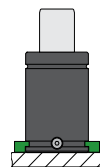
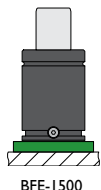
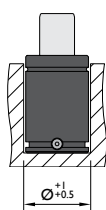
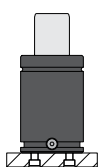

Flange must not support spring's force

Flanges

BFE-1500

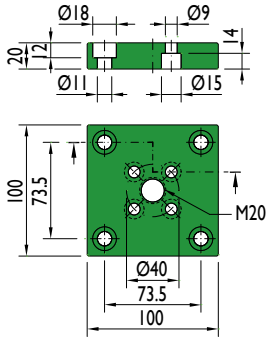

GR-1500

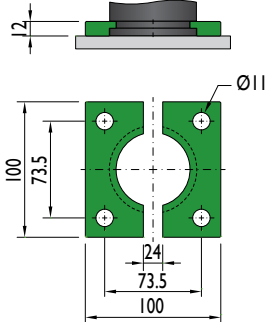

XC-1500

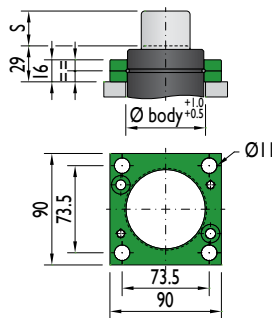

CS-1500

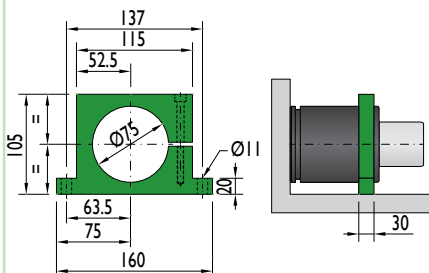

Flange must not support spring's force





PSA
E24.54.815.G

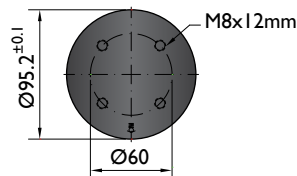
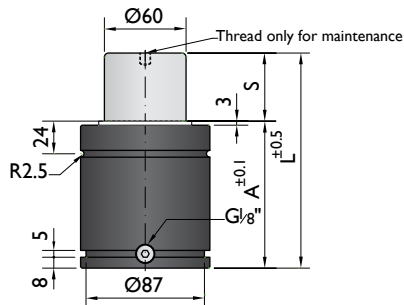

Force / Pressure

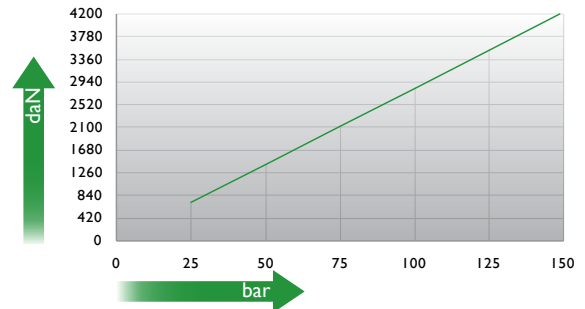

Max. strokes / minutes

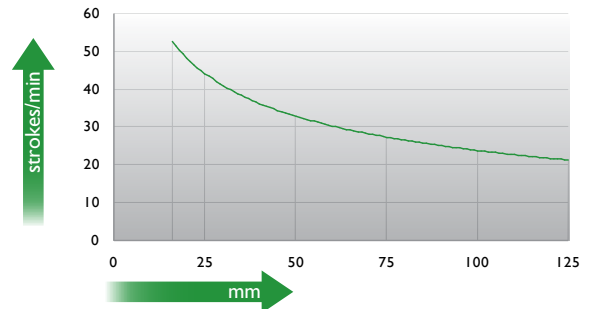

Ordering example: 4 x GGS C 04200 080

Order No.	NITROGAS	S mm	L mm	A mm	F ₀ daN (20°C, 150 bar)	F daN (20°C, 150 bar)	kg
GGC C 04200 016	KP-4200-16	16	90	74	4200	6500	2.82
GGC C 04200 025	KP-4200-25	25	108	83		6900	3.05
GGC C 04200 050	KP-4200-50	50	158	108		7500	3.69
GGC C 04200 080	KP-4200-80	80	218	138		7800	4.45
GGC C 04200 100	KP-4200-100	100	258	158		7900	4.96



Use KP model only if it is not possible to assemble an ISO gas spring.



Pressure medium	N ₂	Working temperature	0-80°C	Min. security stroke	10%
Max. Charging pressure	150 bar	Temperature related force increase	+0.34%/°C	Repair Kit	KIT KP-4200
Min. Charging pressure	25 bar	Max. working speed	1.6 m/s	Linkable	G1/8"

Mounting possibilities



The gas spring must be fixed by flanges or by bottom with screws and lock washer.

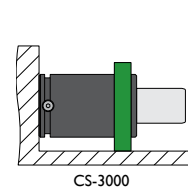
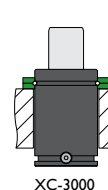
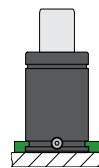
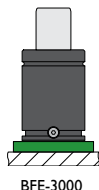
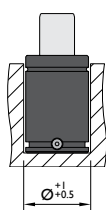
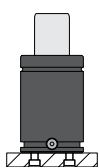

Flange must not support spring's force

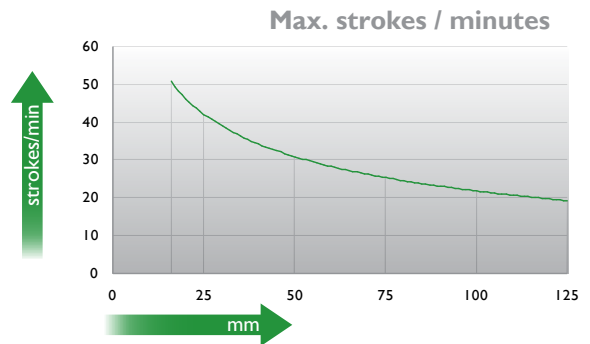
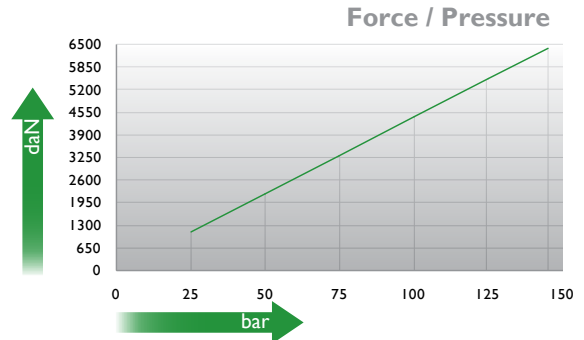
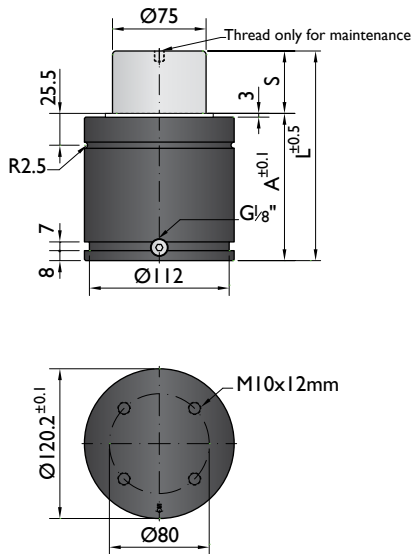

Ordering example: 4 x GGS C 06600 080

Order No.	NITROGAS	S mm	L mm	A mm	F_0 daN	F daN		kg
					(20°C, 150 bar)			
GGS C 06600 025	KP-6600-25	25	118	93		10300	No	6.24
GGS C 06600 038	KP-6600-38	38	144	106		10700	No	6.79
GGS C 06600 050	KP-6600-50	50	168	118	6600	11500	No	7.58
GGS C 06600 080	KP-6600-80	80	228	148		11100	Yes	8.46
GGS C 06600 100	KP-6600-100	100	268	168		11000	Yes	9.10



Use KP model only if it is not possible to assemble an ISO gas spring.



Pressure medium	N ₂	Working temperature	0-80°C	Min. security stroke	10%
Max. Charging pressure	150 bar	Temperature related force increase	+0.34%/°C	Repair Kit	KIT KP-6600
Min. Charging pressure	25 bar	Max. working speed	1.6 m/s	Linkable	G1/8"

Mounting possibilities



The gas spring must be fixed by flanges or by bottom with screws and lock washer.

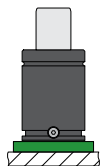
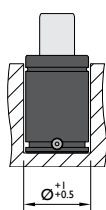
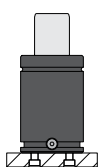

BFE-5000

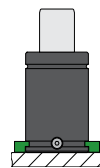

GR-5000

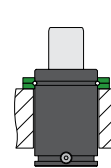

XC-5000

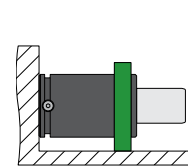

CS-5000

Flange must not support spring's force

Flanges

BFE-5000

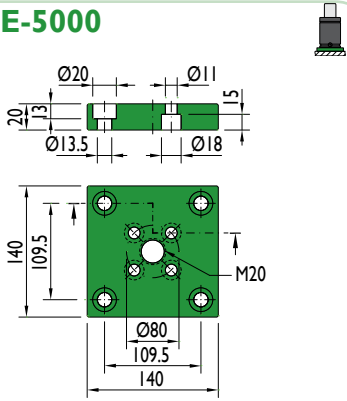

GR-5000

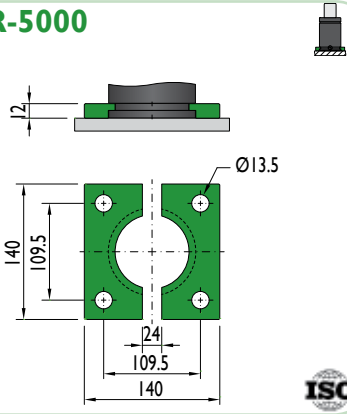

XC-5000

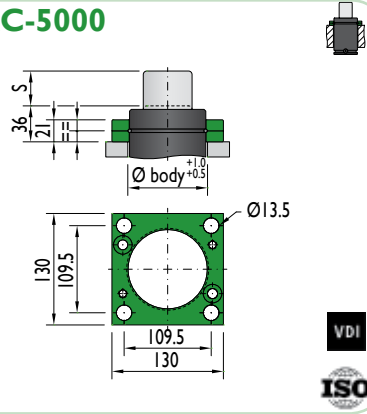

CS-5000

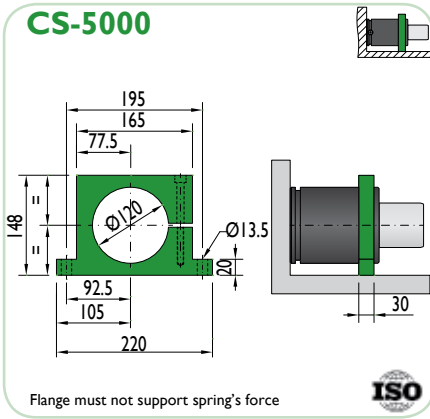

Flange must not support spring's force



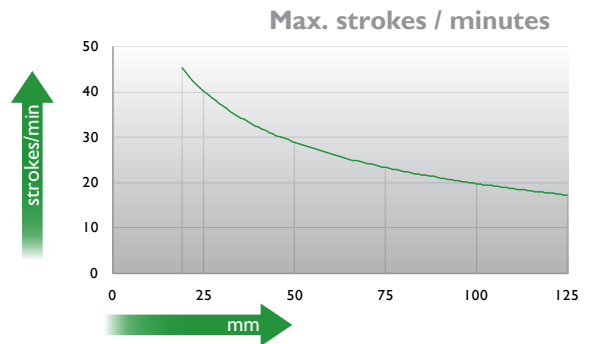
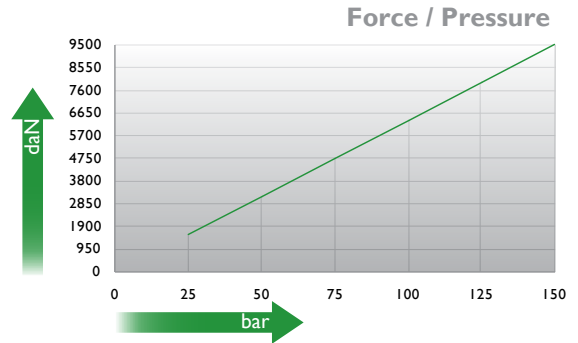
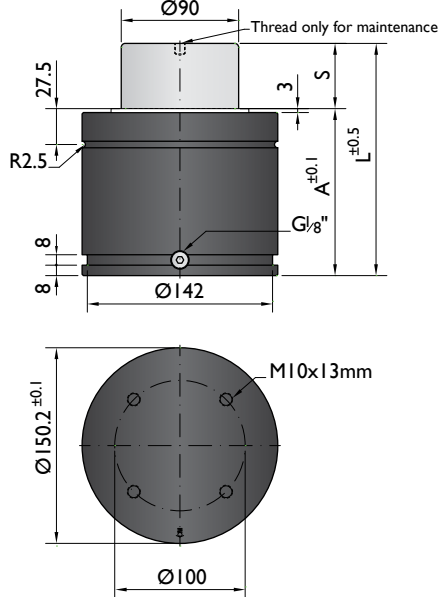

Ordering example: 4 x GGS C 09500 080

Order No.	NITROGAS	S mm	L mm	A mm	F ₀ daN	F daN		kg
					(20°C, 150 bar)			
GGS C 09500 063	KP-9500-63	63	204	141		17400	Yes	14.73
GGS C 09500 080	KP-9500-80	80	238	158	9500	17300	Yes	15.97
GGS C 09500 100	KP-9500-100	100	278	178		17200	Yes	16.53



Use KP model only if it is not possible to assemble an ISO gas spring.



Pressure medium	N ₂	Working temperature	0-80°C	Min. security stroke	10%
Max. Charging pressure	150 bar	Temperature related force increase	+0.34%/°C	Repair Kit	KIT KP-9500
Min. Charging pressure	25 bar	Max. working speed	1.6 m/s	Linkable	G1/8"

Mounting possibilities



The gas spring must be fixed by flanges or by bottom with screws and lock washer.

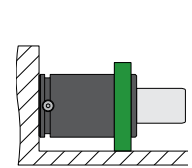
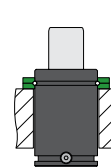
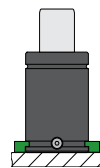
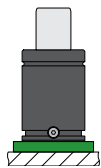
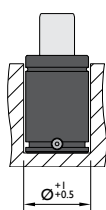
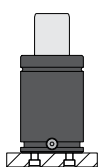

Flange must not support spring's force

Flanges

BFE-7500

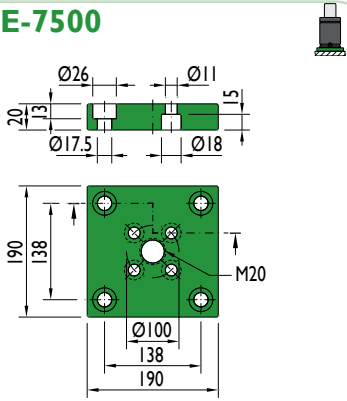

GR-7500

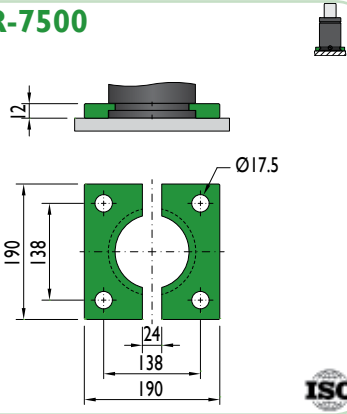

XC-7500

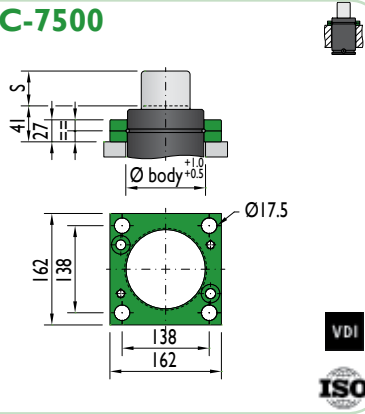

CS-7500

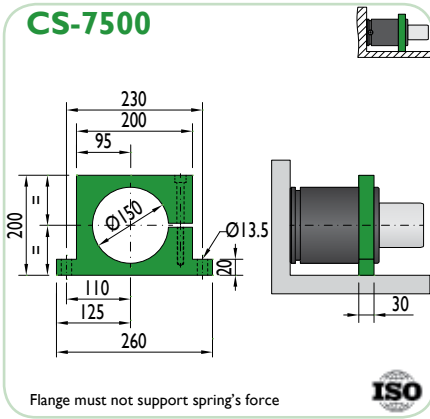

Flange must not support spring's force



Linking system selection

Linking gas springs allows to monitor and adjust pressure as well as charge and discharge the gas springs from outside the die. It also ensures a balanced force among several gas springs (with similar technical features).

NITROGAS offers various types of hoses, adapters and control panels to design a customized linked system. Those components are divided into 3 different systems: Micro Systems, EO24 Systems and Minimes Systems.

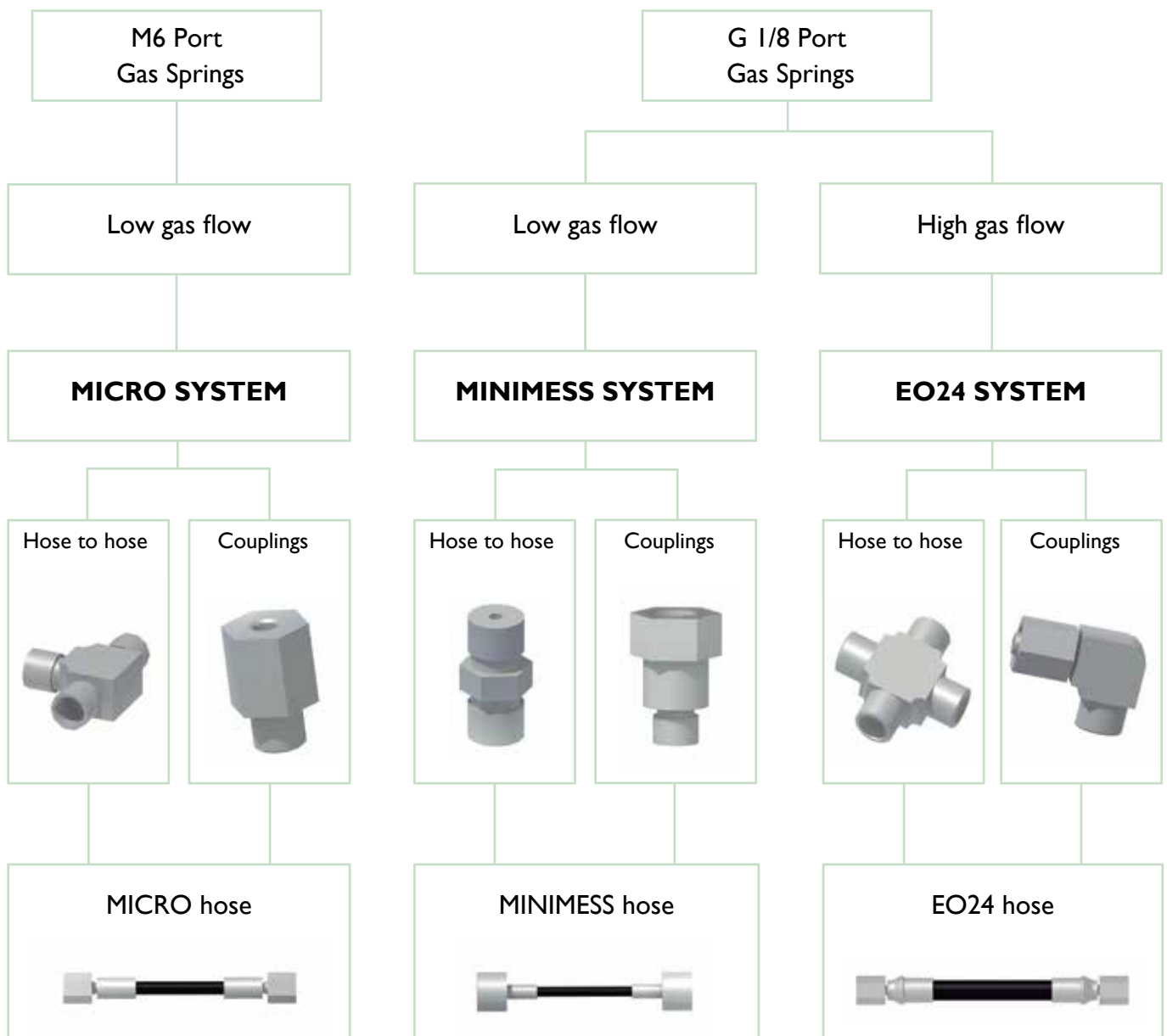

The possibility of being or not connecting, as well as the connection type (M6 or G1/8") of each gas spring model is indicated in the specification sheet of each model.



Safety standards

When looking for safety and optimum performance life in a hose system creation, it is important to consider the following points:

- Before converting gas springs from self-contained to linked mode and remove the valve, **ensure the gas spring is completely discharged.**
- Place the control panel in the tool where it will be protected from mechanical damage, and on a higher level than the gas springs to minimize loss of lubrication oil when discharging the gas.
- Use only nitrogen (N_2) gas. The use of other types of gas can result in personal injury or failure of the gas spring/control panel.
- Do not exceed the maximum pressures and temperatures given for the hoses and gas springs.
- All valves on the control panel should be closed during operation.
- All gas springs hosed together should be of the same size and model.

NITROGAS provides training courses on piping gas springs systems.

Mounting arrangement

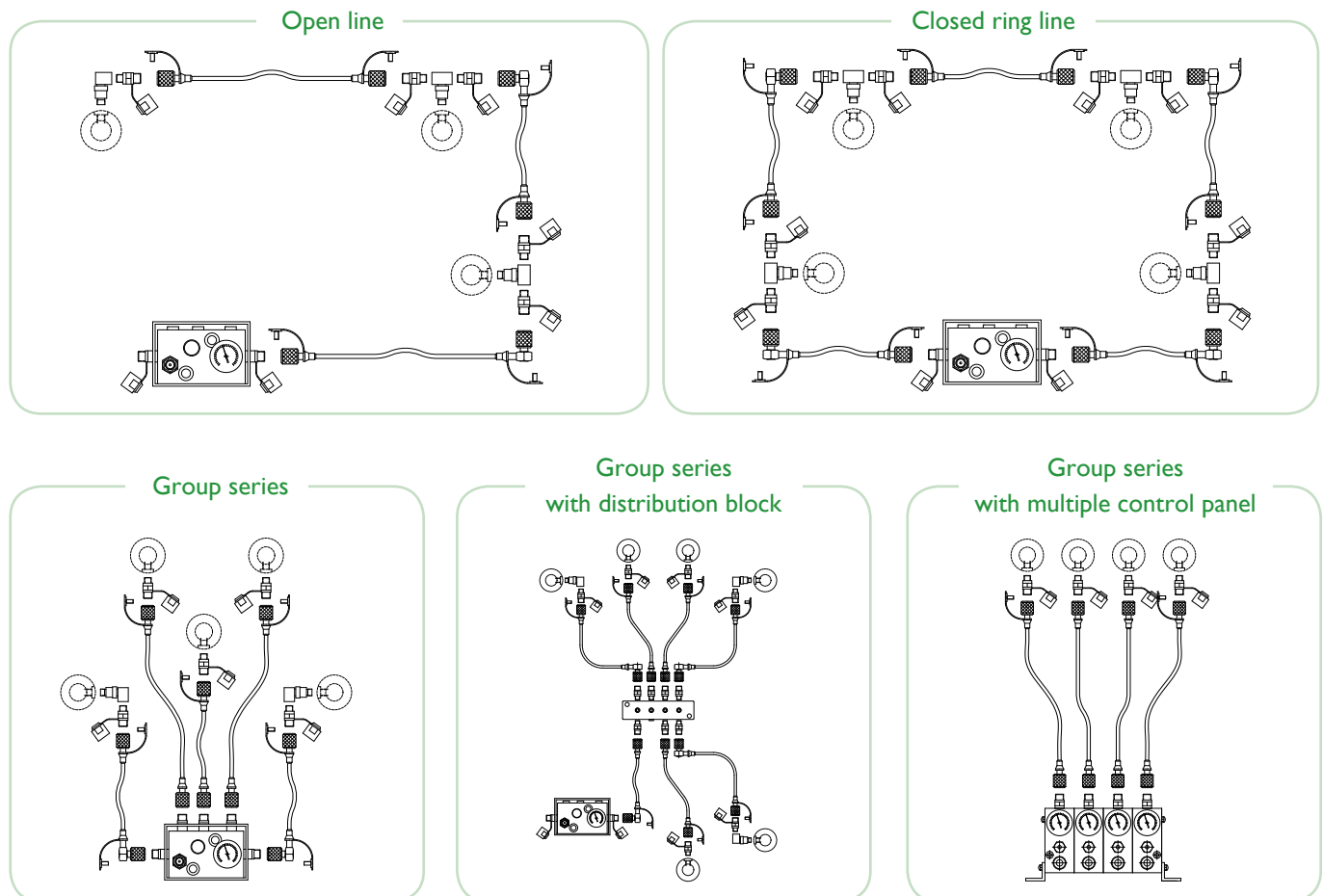

Specification for installation

Follow the instruction below to ensure functionality and maximum service life for hose connection. Ensure that all hoses and adaptors are perfectly clean before assembling.

1. The hose length must provide a certain amount of play.
2. Do not twist the longitudinal marking during assembly.

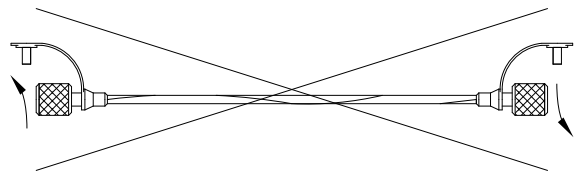
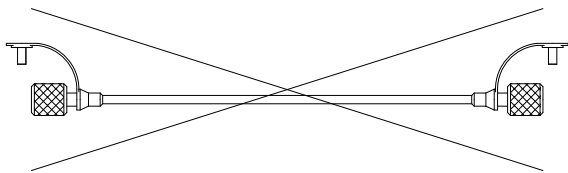

3. Choose the appropriate fittings to avoid sharp bends in the hose.
4. Any bends in the hose must have at least the recommended minimum radius.

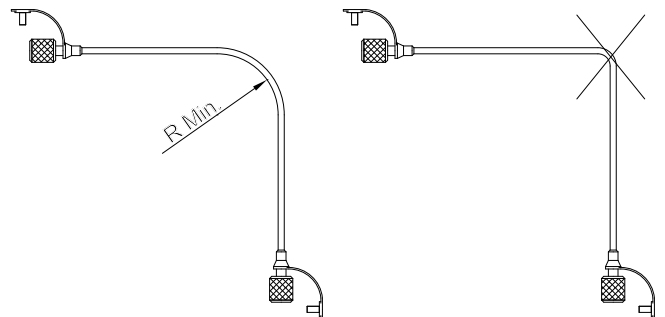
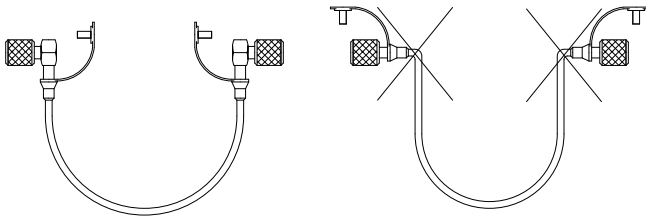

5. Fix the hose correctly to avoid mechanical damage. We recommend using RM-108 clips to fix the hose.
6. The hose must have at least a minimum drop length.

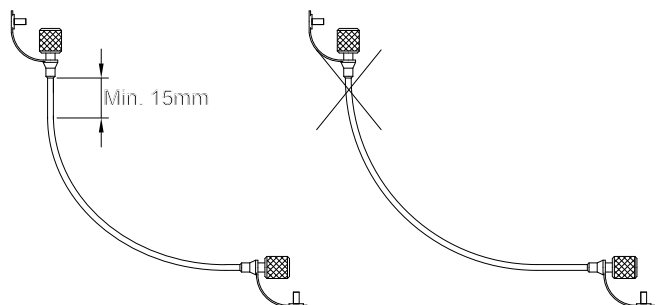
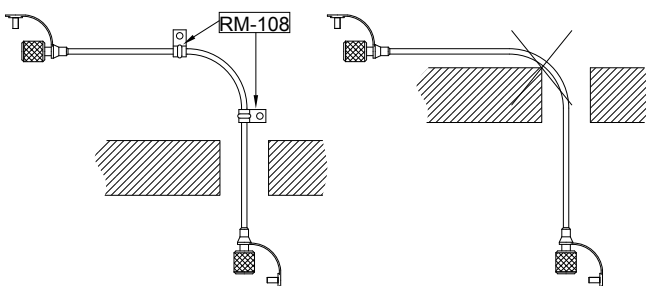

Micro System

Hoses

Basic information	
Material	Polyamide
Dimension	External Ø 4.9 mm Internal Ø 2 mm
Min. bend radius	20 mm
Max. working pressure	630 bar
Min. burst pressure	1900 bar
Operating temperature	-40°C / +100°C
Minimum length	200 mm

LKI

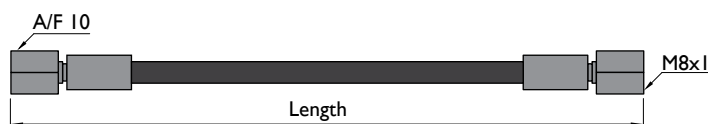

Ordering example: LKI-Length in mm

4 x LKI-750

Micro System

Terminals

TERM-LK

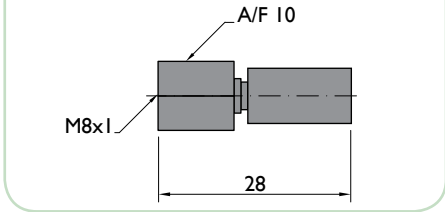

Hose to hose

RC-605

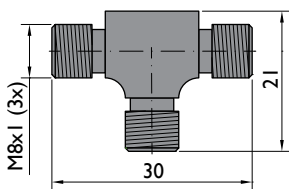

RC-606

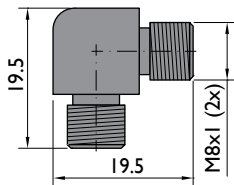

RC-607

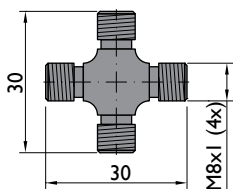

RM-609

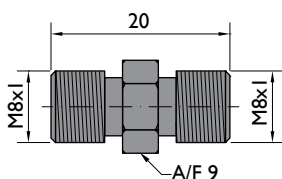

Couplings

RM-601

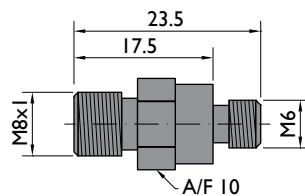

RM-602

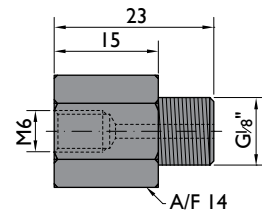

RM-603

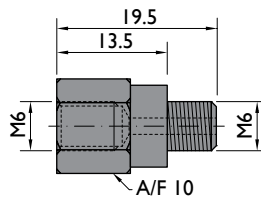

RM-604

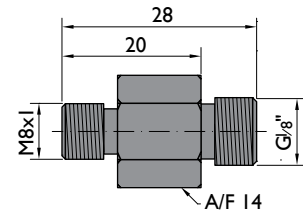

RM-605

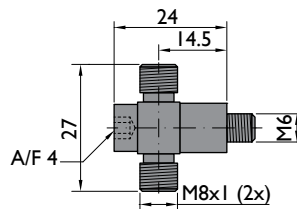

RM-606

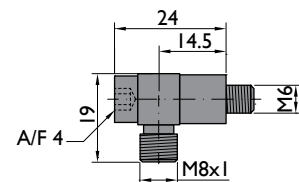

EO24 System

Hoses

Basic information	
Material	Polyamide
Dimension	External Ø 10.7 mm Internal Ø 4.8 mm
Min. bend radius	40 mm
Max. working pressure	345 bar
Min. burst pressure	1380 bar
Operating temperature	-40°C / +100°C
Minimum length	300 mm

LD1



LD2

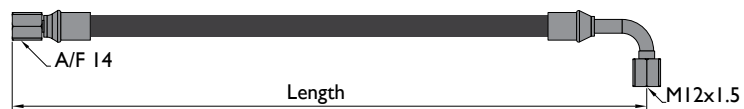

LD3

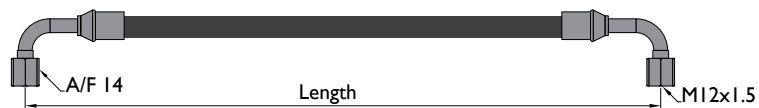

LD4

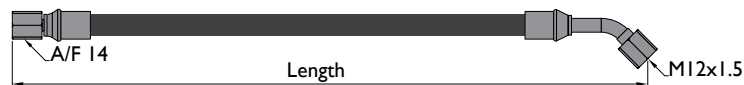

LD5



LD6

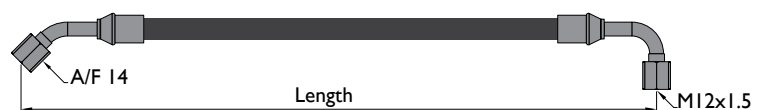

Ordering example: LD(1,2,3,4,5,6)-Length in mm

4 x LD1-750

EO24 System

Terminals

TERM-LDR

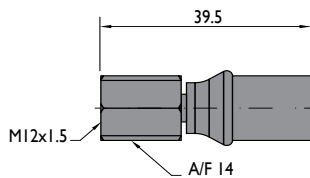

TERM-LDC

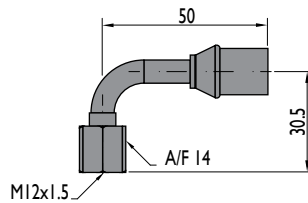

TERM-LDA

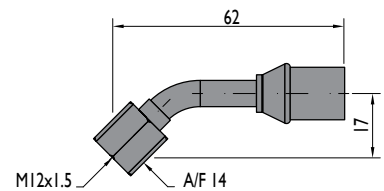

Hose to hose

RC-505

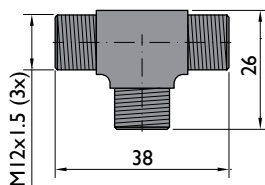

RC-506

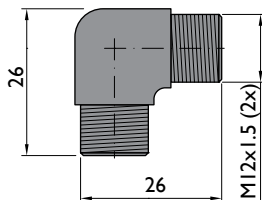

RC-507

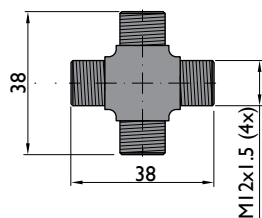

RM-509

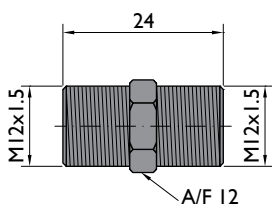

Couplings

RM-501

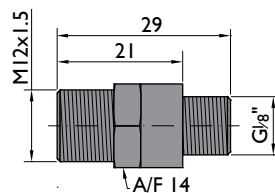

RM-503

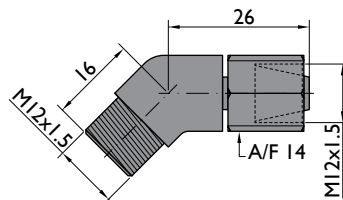

RM-504

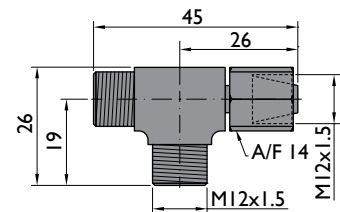

RM-505

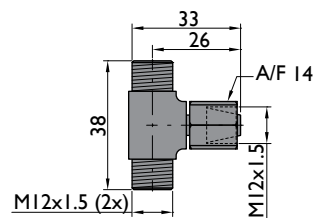

RM-506

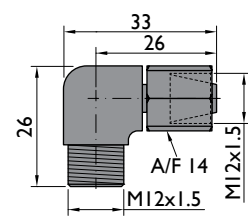

Minimess System

Hoses

Basic information	
Material	Polyamide
Dimension	External Ø 4.9 mm Internal Ø 2 mm
Min. bend radius	20 mm
Max. working pressure	630 bar
Min. burst pressure	1900 bar
Operating temperature	-40°C / +100°C
Minimum length	200 mm

LM1

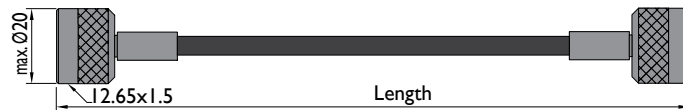

LM2

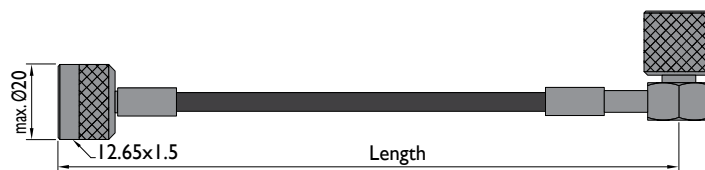

LM3

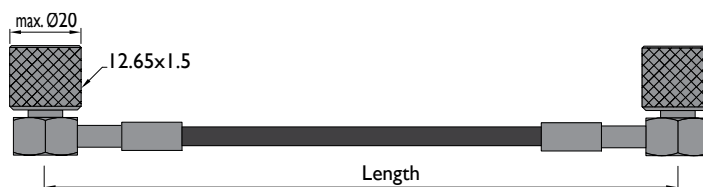

Ordering example: LM(1,2,3)-Length in mm

4 x LM1-750

Minimess System

Terminals

TERM-RECTO

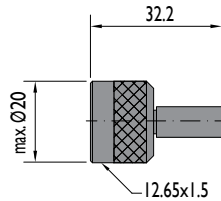

TERM-CODO

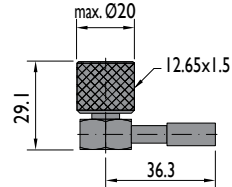

Hose to hose

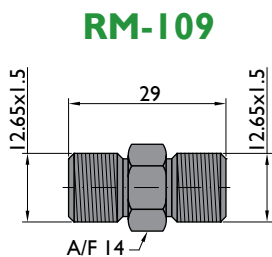

Couplings

RM-101*

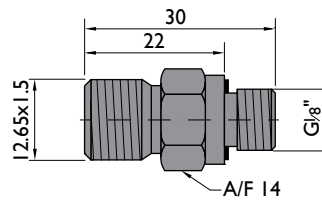

RM-201

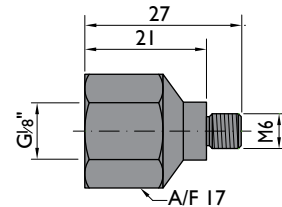

RM-103

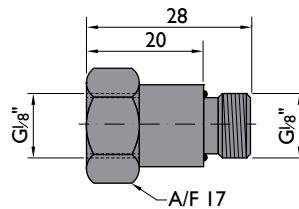

RM-105

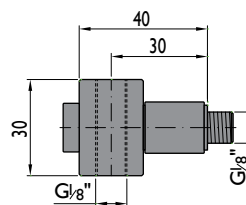

RM-106

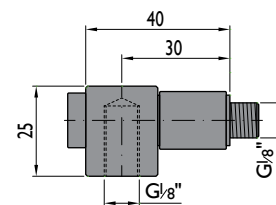

MP-125

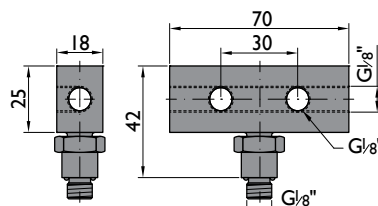

* Includes a non-return valve to keep the pressure on each gas spring individually when removing the hoses.

Control panels

PCM-8

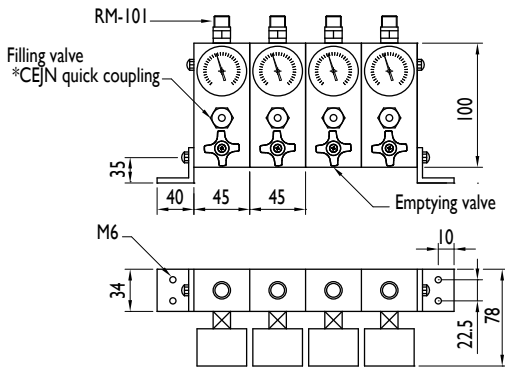

Minimess

PC-I

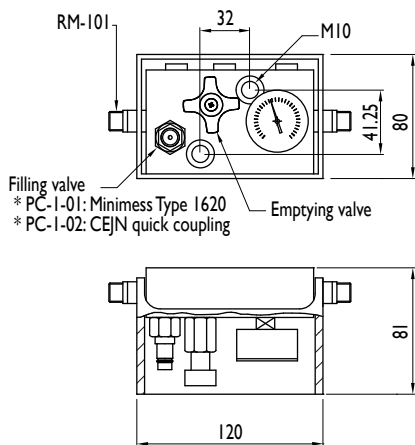

Minimess

PC-2

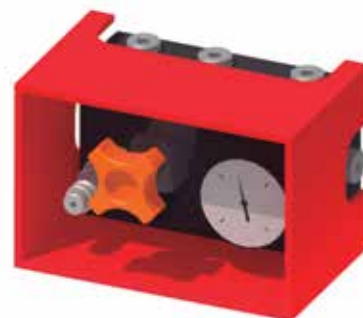
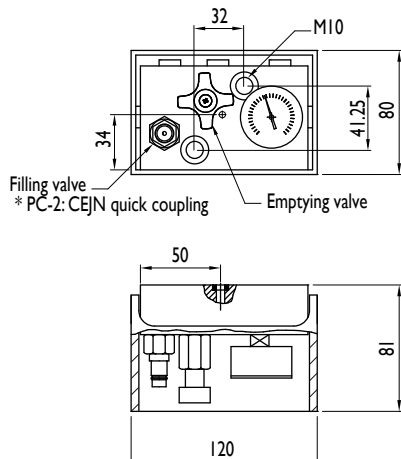

Minimess

Control panels

PC-4

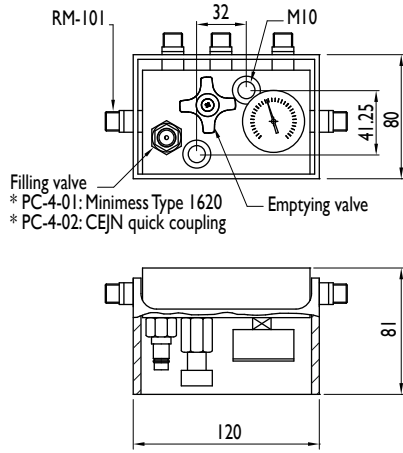

Minimes

PC-5

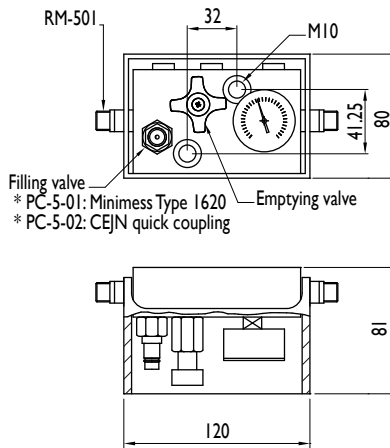

EO24

PC-6

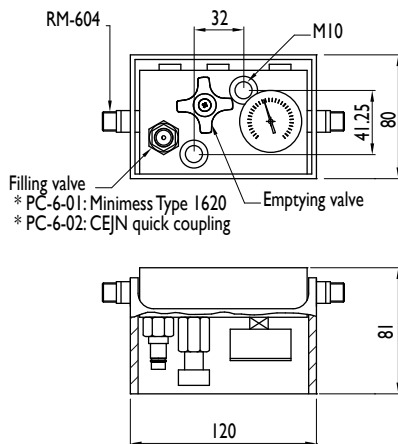

Micro



Distribution blocks

Distribution blocks simplify piping to multiple cylinders with a uniform system pressure. NITROGAS offers distribution blocks with M6 and G 1/8 connections.

RDM-4

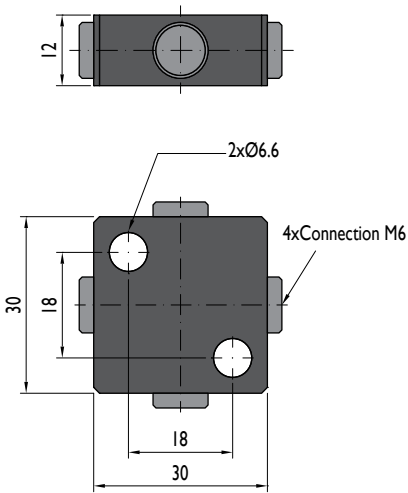

RD-4

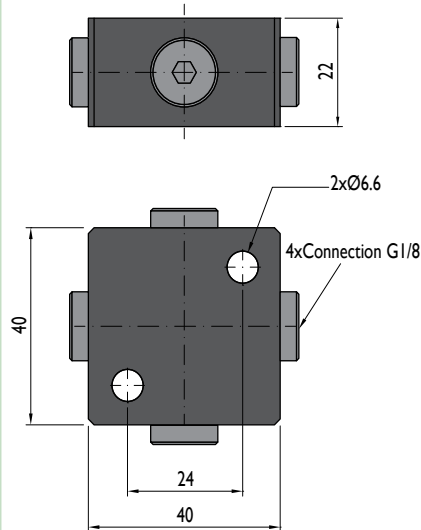

RDH-6

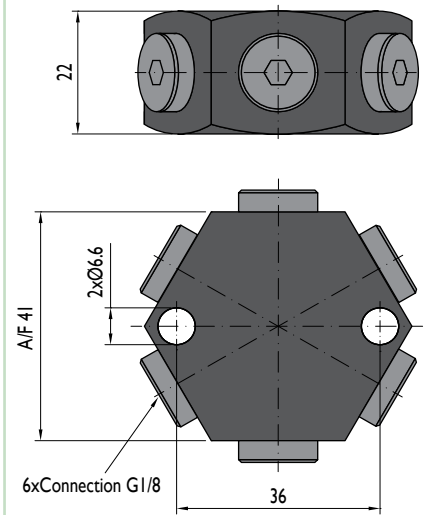

RD-6

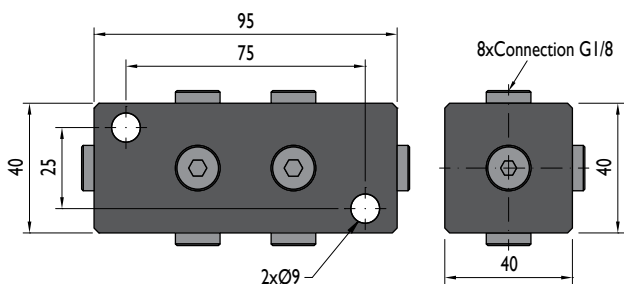

RD-9

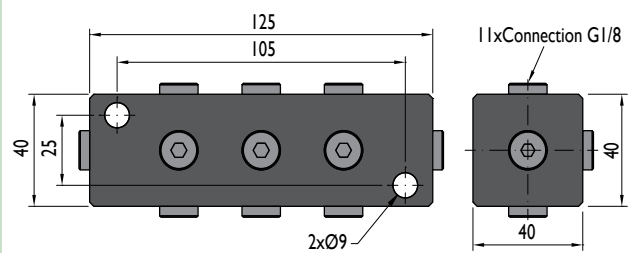

RD-12

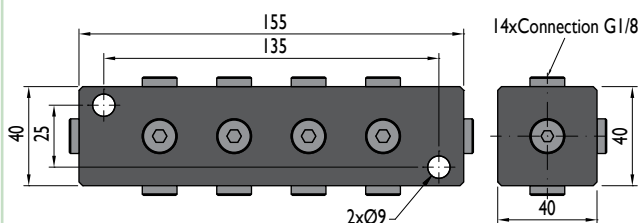

RD-xx

Number of connections by request

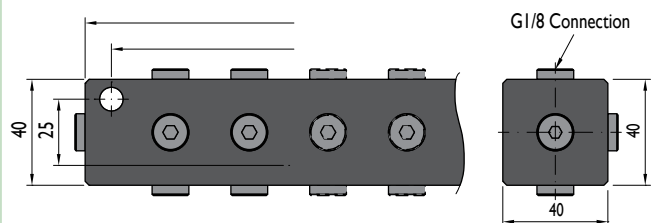

Support plates

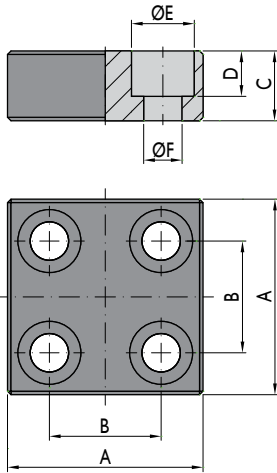

	A mm	B mm	C mm	D mm	E mm	F mm
SPC-150	40	21	15	10	15	9
SPC-250	40	21	15	10	15	9
SPC-500	40	21	15	10	15	9
SPC-750	56	32	20	13	18	11
SPC-1500	56	32	20	13	18	11
SPC-3000	90	67	20	13	18	11
SPC-5000	90	67	20	13	18	11
SPC-7500	140	110	20	13	18	11
SPC-10000	140	110	20	13	18	11

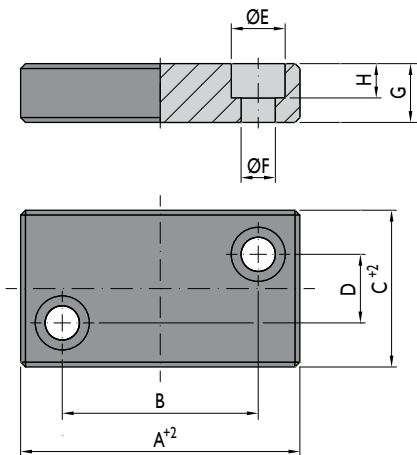

	A mm	B mm	C mm	D mm	E mm	F mm	G mm	H mm
SPV-150	50	32	25	8	11	7	12	7
SPV-250	50	32	25	8	11	7	12	7
SPV-500	55	40	30	14	11	7	12	7
SPV-750	70	48	35	14	15	9	15	9
SPV-1500	75	56	50	30	15	9	15	9
SPV-3000	85	66	60	40	15	9	15	9
SPV-5000	100	72	80	56	18	11	20	11
SPV-7500	110	85	100	75	18	11	20	11
SPV-10000	130	100	110	80	18	11	20	11

Identification plates

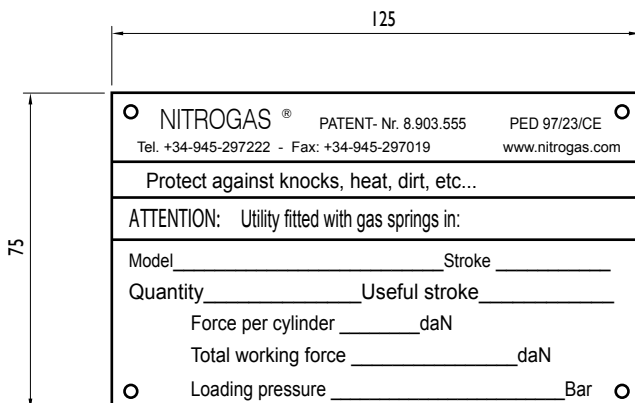

NITROGAS recommends identifying tools containing high pressure nitrogen gas springs to ensure the proper handling of the gas springs.

Reference	Language
PI-119-1	Spanish
PI-119-2	English
PI-119-3	German
PI-119-4	French

Gas Springs



A wide range of high quality gas springs and accessories to use in press dies or injection moulds.

Controllable gas springs (CPC)



CPC gas spring allows a controlled stop at the end of rod stroke. This stop is highly reliable, always performing at the same position and with a 100% guarantee.

Cam units

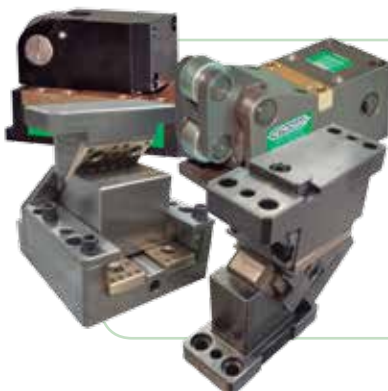

Designed to use the power of the press to punch, blend or form in different directions from the direction of the press tool.



Solutions for the storage tools

Designed to replace conventional distance blocks.

CS gas springs: Die storage cylinder

- Do not work during the production

SG gas springs: Stocking cylinder

- Work as a standard gas spring
- ISO standard dimensions but longer life than standard gas springs

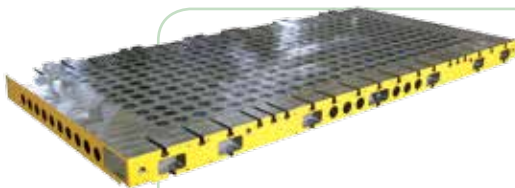

Manifold plates

Designed to replace the hosing connection of gas springs by threading the gas springs directly on the plate. The system allows a more flexible distribution of the gas springs, reduces the leaking points and guarantees that all the gas springs have the same pressure.



Guide rail lifters

Designed to replace and simplify the guide pillar, gas spring and retainer screw structure when raising the sheet or the workpiece.



CAD files of the product can be downloaded FREE from our website:
<http://www.nitrogas.com/es/Downloads.aspx>



Commercial

 comercial@nitrogas.com



Training

 training@nitrogas.com



Engineering

 engineering@nitrogas.com



Maintenance

 maintenance@nitrogas.com



Contact hours

NITROGAS offers 24 hs contact service.

NITROGAS



nitrogas@nitrogas.com
www.nitrogas.com

NITROGAS